

■ KIRIKO-Automatic Shaving Compactor

Contributes to ISO 14000 – Environment, Reuse & Recycle.

Compacted Chips give higher yield during melting in the furnace.

Suitable for Ferrous & Nonferrous machined metal chips.

You can hold shavings under discriminatory control.

In the Process of compacting wet chips, the coolant can be separated.

Compacted cakes are safe to handle compared to sharp chips.

Compacted cakes will fetch a higher price as compared to loose scrap.



Specifications

Model	YK-40V-10 YK-40V-10B YK-40V-10C YK-40V-10CR	YK-80V-10 YK-80V-10B YK-80V-10C YK-80V-10CR	YK-80V-20 YK-80V-20B YK-80V-20C YK-80V-20CR	YK-80V-20CRHS
Item				
Product Dimensions	Dia. 70 x 65mm	Dia. 100 x 65mm	Dia. 70 x 65mm	Dia. 70 x 65mm
Compressing Pressure	1000 Kgf/cm ²	1000 Kgf/cm ²	2000 Kgf/cm ²	2000 Kgf/cm ²
Operating Time	About 26s/ dry cycle (excluding charging time)	About 30s/dry cycle (excluding charging time)		About 8s/dry cycle (excluding charging time)
Main Motor	3.7 KW			22 KW
Charging Motor	0.18 KW			1.48
Bridge Breaker Motor	0.18 KW			-
Power Supply	AC 400/415 V (50/60Hz) 3 Phase			
Approx. Mass	700 Kg	1200 Kg	2500 Kg	

* Contact YUKEN for availability details.

Model Number Designation

YK	-40	V	-10	※	※	※※
Series Number	Cylinder Output	Compressing Direction	Compressing Pressure	Shaving Bridge Breaker	Crusher Type* ²	Design No.
YK: Automatic shaving compactor	40 : 40000 Kgf (40t)	V : Vertical	10 : 1000 Kgf/cm ²	None : Without shaving bridge breaker	C : Screw type of crusher CR : Push-in type of crusher	*1
				B : With shaving bridge breaker	-	
	80 : 80000 Kgf (80t)		10 : 1000 Kgf/cm ² 20 : 2000 Kgf/cm ²	None : Without shaving bridge breaker	C : Screw type of crusher CR : Push-in type of Crusher CRHS : High speed crusher	
				B : With shaving bridge breaker	-	

*1 Contact our sales for latest design number.

*2 Consult YUKEN for availability.

Accessories

● **Solid Piece Separator.**

Note: This item is an accessories sent to BOSCH, Bangalore along with the machine.

● **Storage hopper with conveyor.**

Note: This item is an accessories sent to IFEX exhibition, Delhi along with the machine.

- YK-40V
- YK-40V-※-B
- YK-80V

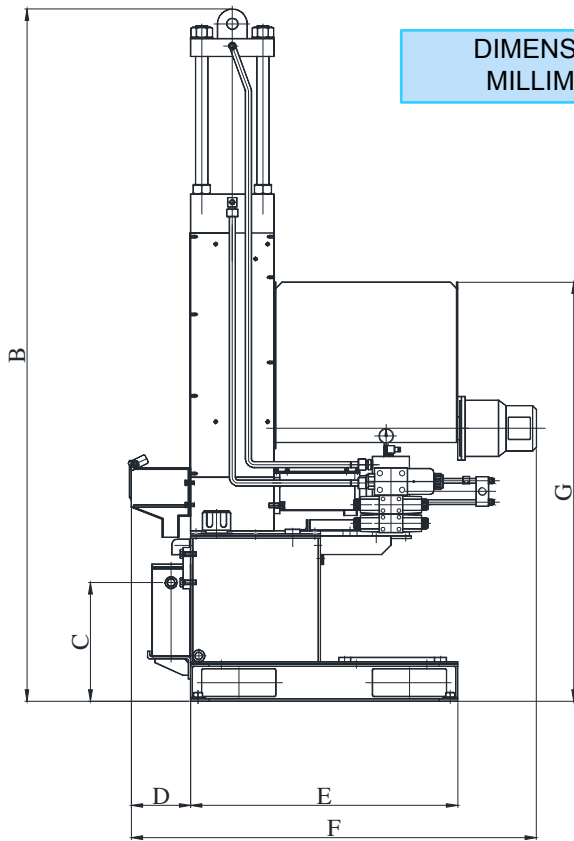
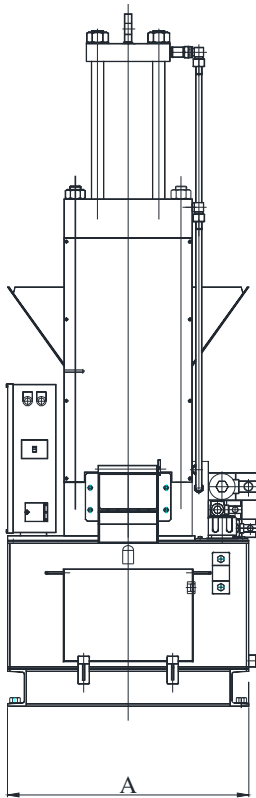
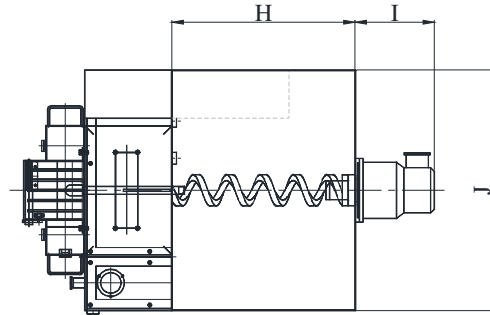

DIMENSIONS IN MILLIMETRES

Model	A	B	C	D	E	F	G	H	I	J	Dry Cycle
YK-40V	650	1895	530	160	720	1225	1132	495	212	650	26
YK-40V-※-B											
YK-80V	735	2125	640	10	950	1300	1242	495	320	650	30

- YK-40V-※ C
- YK-40V-※ CR
- YK-80V-※ C
- YK-80V-※ CR

DIMENSIONS IN MILLIMETRES

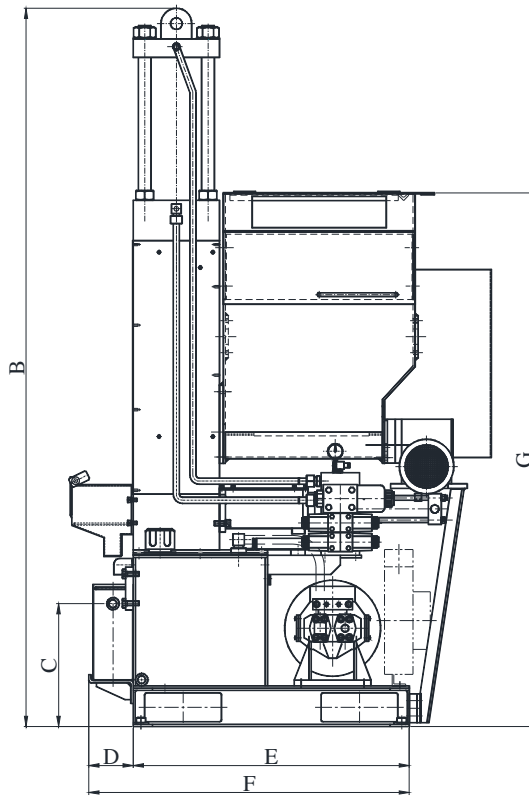
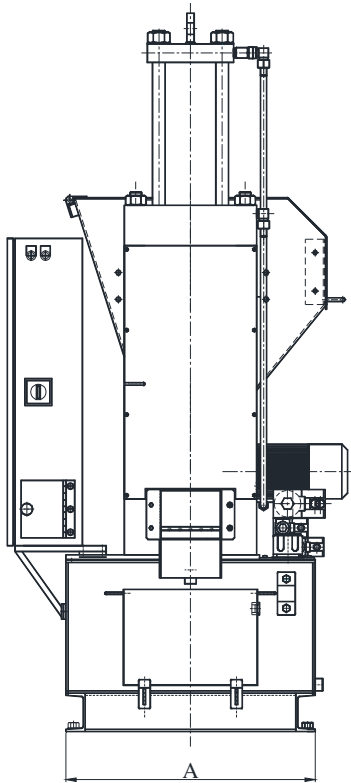
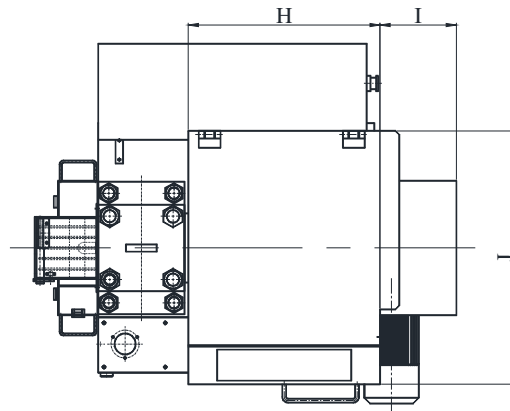

Model	A	B	C	D	E	F	G	H	I	J	Dry Cycle
YK-40V	650	1895	530	160	720	High Pressure Model 1062 Low Pressure Model 1092	1112	500	168	662	26
YK-80V	735	2090	445	10	900	1159	1511	500	199	660	30

● YK-80V-※ CRHS

DIMENSIONS IN MILLIMETRES

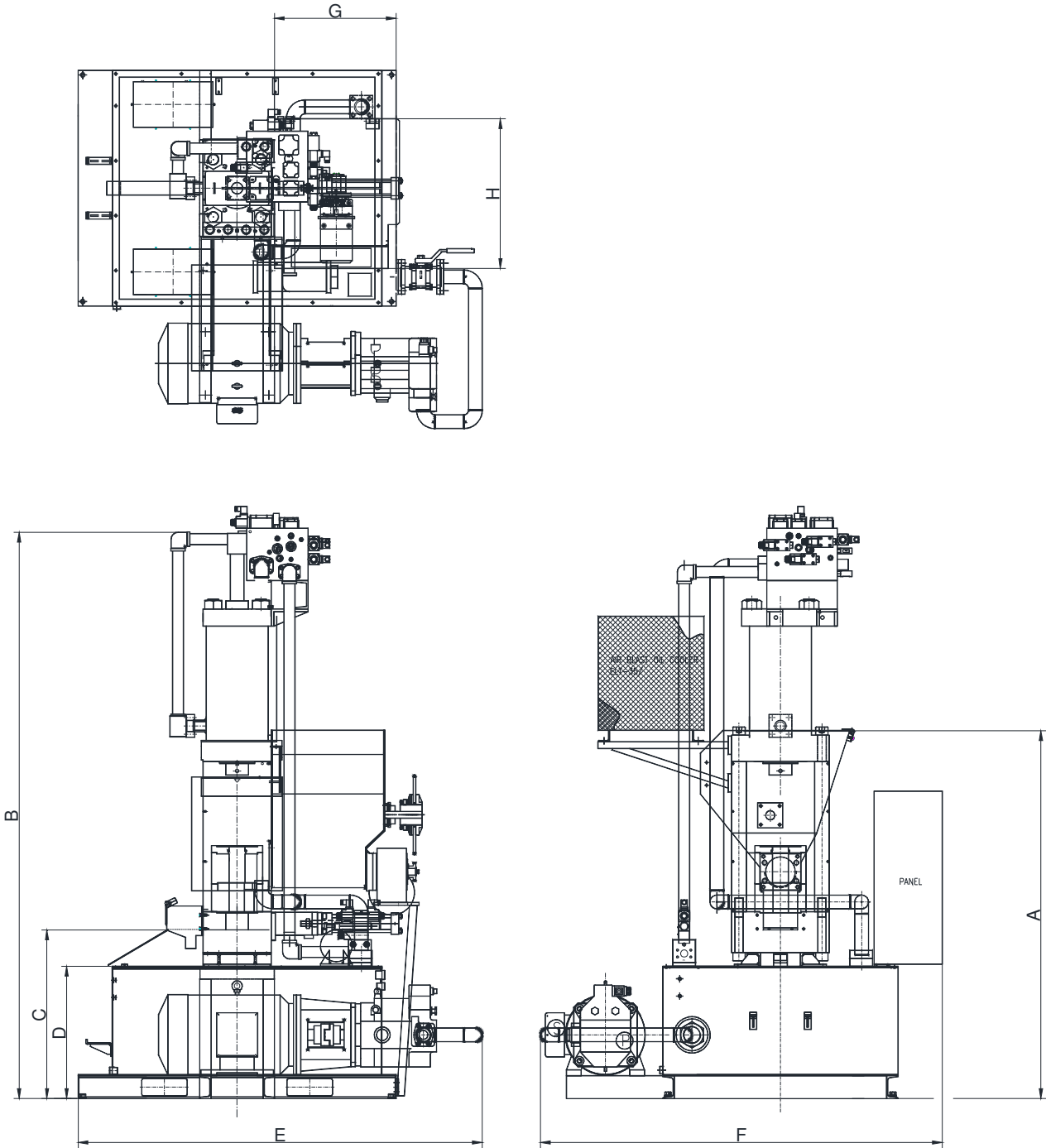

Model	A	B	C	D	E	F	G	H
YK-80V-20CRHS	1616	2505	740	581	900	1800	500	658