



EATON

Powering Business Worldwide

Table of contents

Description	Page No.
General specifications	3-5
Applications, features, and benefits	3
Specifications	4
Principles of operation	6 - 7
Post-compensated circuit	7
Pre-compensated circuit	7
Order example	8 - 9
Valve bank worksheet	8
Tie rod kits and paint	9
Dimensional information	10 - 11
CLS180 with manual actuation and enclosed lever box	10
CLS180 with electrohydraulic actuation and lever override	11
Typical performance curves	12 - 14
Valve bank inlet	15 - 18
Model code structure	15
Inlet build type and configuration	16
Inlet relief and dump valve options	17
Working sections	19 - 27
Model code structure	19
Compensation options	20
Hydraulic actuation options	21
Electrohydraulic actuation options	22
Manual actuation options	23
Spool flow and spool type	24
Spool stroke limiter and position indicator	25
Section load sense and port relief options	26
Valve bank end cover	28 - 29
Model code structure	28
End cover options	29
Special features	30 - 31
Parallel connection – multiple valve banks	30
High Pressure Carry Over (HCPO)	31
Installation and maintenance	32 - 35
General torque specifications	32
Hydraulic fluid recommendations	34

Eaton's CLS Load Sense Sectional Mobile Valve

Eaton's new CLS load sensing sectional mobile valve is a pre and post compensated mobile valve with a highly versatile design. This modularity is demonstrated through the availability of valve banks with up to 10 sections, a number of spool types and actuation options, mid-inlets, custom inlet manifolds and transition plates. With this flexibility, you can design your valve to meet the requirements of your machine. Add in the ability to install

both pre and post compensated sections in the same valve bank; the CLS allows you to prioritize work functions to accelerate productivity, improve machine efficiency, and enhance the safety characteristics of the machine.

Improve your machine performance with the newest load sensing valve to market, Eaton's CLS.

Features and benefits

- Load sense circuit design is a parallel circuit with closed center spools. Available with inlet options to support both fixed and variable displacement pumps
- Both pre and post comp sections available in same valve assembly
- Flexible design with up to 10 sections
- Electro-proportional spool control achieved through a PWM proportional pressure reducing solenoid valve controlling pilot pressure to spool ends to maintain spool position
- Optional manual, hydraulic and electrohydraulic controls with lever overrides
- Special features available for additional design flexibility:
 - Local load sense relief on pre and post compensated sections
 - Flow control device on local section compensator
 - Adjustable spool stroke limiting device
 - Parallel connection of multiple valve banks
 - High pressure carry-over function
 - Work port relief with anti cavitation
 - Available fourth position float and regeneration spools

Typical applications

- Excavator – multiple sizes
- Forestry
- Refuse trucks
- Forklift
- Agricultural machinery
- Truck mounted cranes
- Marine



Specifications and performance

CLS180 Load Sense Sectional Mobile Valve

Rated pressure	Inlet	350 bar (5076 psi)
	Tank port	25 bar (362 psi)
Rated inlet flow		220 lpm (58.1 gpm)
Rated workport flow - post compensated	180 lpm (47.6 gpm) @ 17 bar at differential pressure	
Fluid cleanliness and viscosity	See Hydraulic Fluid Recommendations Bulletin 03-401	
Ambient operating temperature range	-40°C / 60°C (-40°F / 140°F)	
Oil temperature operating range	-25°C / 80°C (-16°F / 176°F)	
Construction	Sectional	
Work sections	1-10	
Maximum leakage, cylinder workport to tank	12 cc per minute at 100 bar (1450 psi)	
Port types	Inlet ports	BSP (G3/4 P&T, G1/4 LS and Pilot Drain) SAE (-12 P&T, -6 LS and Pilot Drain) G1/2 BSP (G1/4 Pilot if Hydraulic)
	Tank ports	SAE, -10 (SAE -6 Pilot if Hydraulic)
Work section options	Spools	Double Acting (4 way) Cylinder Bi-Directional (4 way) Motor, Full Open to Tank in Neutral
	Actuation	Hydraulic with Top Ports Hydraulic with End Ports Electrohydraulic with Lever Override Electrohydraulic Only Manual with Enclosed Lever Box Manual with Exposed Spool Connection Manual with Pneumatic Pilot, Pneumatic Ports Downward Manual with Pneumatic Pilot, Pneumatic Top Ports
Coil voltages	12 Volt DC 24 Volt DC	
Coil connectors	Integral Deutsch DT04-2P Amp Jr. Timer	
Electrohydraulic interface	Eaton HFX programmable controllers and Pro-FX™ application software	

General specifications	CLS100	CLS180	CLS250	CLS350
Max number of working sections	10	10	10	8
Sectional nominal thickness (mm)	38	46	54	72
Spool stroke (mm)	7	8	9	11
Rated flow				
Pump flow rate (l/min)	150	220	300	450
A/B work port flow rate (l/min) (Post-compensated/ pre-compensated with 14 bar Δp)	100/65	180	250	350
Rated pressure				
Working pressure inlet port P (bar)	350	350	350	350
Back pressure max				
Max pressure outlet port T (bar) (Under special conditions back pressure can be lower)	25	25	25	25
Compensation type				
Pre compensation	•			
Post compensation	•	•	•	•
Option chart				
LS Signal pressure relief valve	•	•	•	•
Pump pressure relief valve	•	•	•	•
LS signal dump valve (electric 12/24 Vdc)	•	•	•	•
Pump dump valve (electric 12/24 Vdc)	•	•	•	
Spool types				
Double Acting (4 way) Cylinder	•	•	•	•
Double Acting (4 way) Cylinder with 4th Position Float	•			
Bi-Directional (4 Way) Motor, Full Open to Tank in Neutral	•	•	•	•
Double Acting (4 Way/ 3 Position) Cylinder with Regeneration	•			
Spool actuation				
Hydraulic actuation with hydraulic ports	•	•	•	•
Hydraulic actuation with hydraulic ports and lever override	•			
Electrohydraulic proportional actuation	•	•	•	•
Electrohydraulic proportional actuation with lever override	•	•	•	•
Electrohydraulic actuation with hydraulic ports	•			
Electrohydraulic actuation with hydraulic ports and lever override	•			
Manual actuation with enclosed lever box	•	•		
Manual actuation with exposed spool end	•	•		
Manual actuation with pneumatic pilot ports	•	•		
CAN BUS interface actuation		•		
Port relief valve				
Relief valve		•	•	
Anticavitation valve	•	•	•	•
Combined relief and anticavitation valve	•	•	•	•
Cavity machined and plugged	•	•	•	•
Special features				
Spools position sensor	•	•		
Spool stroke limiter	•	•	•	•
Section flow limiter	•	•		
Section load sense pressure limiting relief*	•	•		
Section remote load sense pressure limiting relief*	•	•		

*Applies to local work ports

CLS Load Sense Sectional Mobile Valve

Description

Operating principle

The CLS valve, completely pressure compensated, guarantees great controllability to all actuations, making workport flow dependent only on metering area (spool position). When flow saturation occurs the system reacts by implementing an equal reduction of pressure margin across all spools, generating a proportional reduction of workport flow.

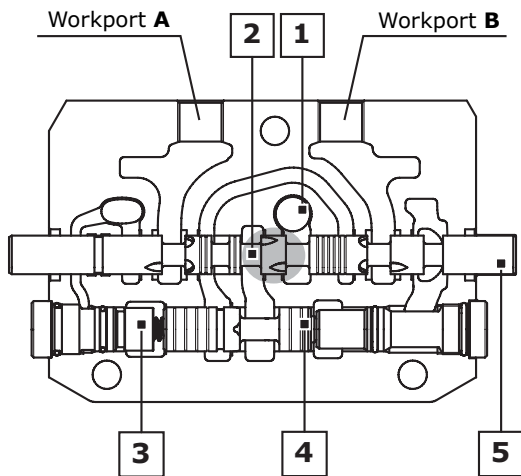

Legend:

1. Inlet line (high pressure)
2. Metering notches
3. Load sensing line
4. Local compensator
5. Metering spool

Single section

Referencing the picture to the left reveals some aspects of system functionality. From the inlet line, the high pressure flow passes across the metering area and down to the local compensator. The metering area, according to the pressure margin, controls the total amount of flow to the work-port selected by the main spool. The load sensing signal, picked up downstream of the local compensator, feeds the common load-sensing line. When a single section is actuated, the local compensator fully opens to the left side, reaching its complete balanced position. The control of the LS system is achieved by the inlet compensator for fixed displacement pumps or the pump compensator for variable displacement pumps.

Multi-section

When two or more sections are actuated, only the function characterized by the highest pressure (dominant) is involved in the LS signal transmission. The other functions become directly dependent on it (slaves). The common LS line transfers the signal from the dominant local compensator to all dependent compensators. Driven by the LS signal, the unbalanced slave compensators activate the pressure compensation creating an artificial pressure drop able to keep pressure margin nominally the same on all the spools. Work-port flow becomes only a function of metering area making the system totally load independent.

Flow sharing section

Saturation occurs when the total amount of flow required by the valve bank is greater than the maximum pump flow rate. In this condition the system is not able to maintain the nominal pressure margin, reducing the margin according to real flow demand. As a result all the local section compensators experience the same LS signal and the same pressure drop is applied to different metering areas, reducing work-port flows proportionally in order to keep all actuations completely under control.

CLS Load Sense Sectional Mobile Valve

Description

The CLS valve line allows the customer the ability to combine pre and post compensated valve sections in the same valve bank. The pre compensated section acts as a priority flow sharing function by diverting flow to the pre compensated function first, then to the remaining sections in the bank.

The following schematics show an example of an all post-compensated system, and a system with an integrated pre-compensated section.

Post-compensated system

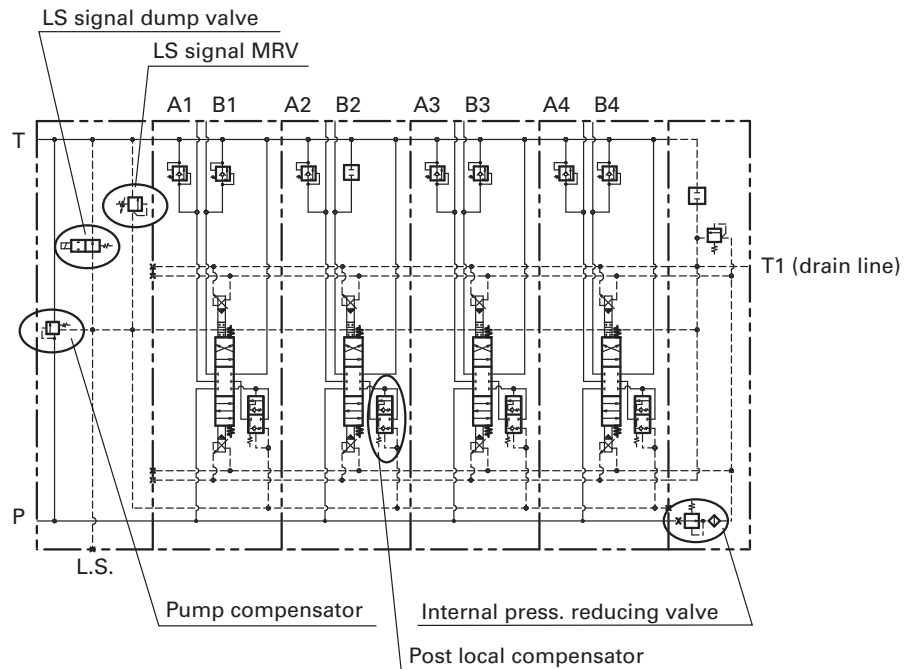

Pre-compensated system

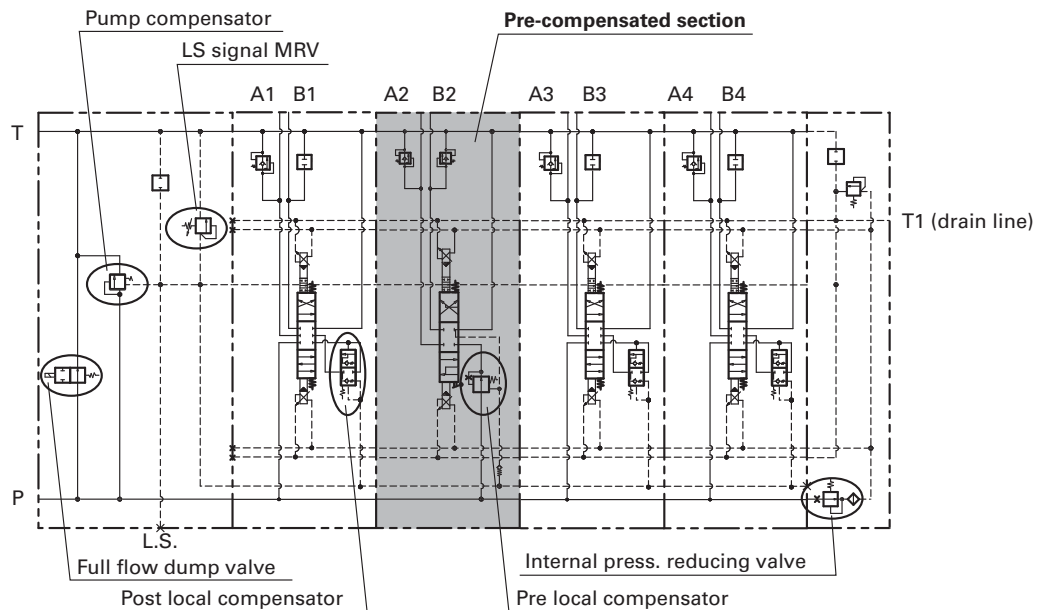

CLS180 Load Sense Sectional Mobile Valve

Ordering example

Valve bank order example

1) Inlet	CLS180-RUS-D210000-ZZ-00-A
2) Section 1	CLS181-PAS-DA120120-Z-P000-P000-Z000-ZZ-00-A
3) Section 2	CLS181-PAS-DA090090-Z-P000-P000-Z000-ZZ-00-A
4) Adaptor plate	6038080-001 - EH ADAPTOR CLS180-CLS100
5) Section 3	CLS101-PAS-DA025025-Z-P000-P000-Z000-ZZ-00-A
6) Section 4	CLS101-PAS-DA025025-Z-P000-P000-Z000-ZZ-00-A
7) Section 5	CLS101-PFS-DA10010-C-P000-P000-Z000-ZZ-00-A
8) Section 6	CLS101-PFS-DA035035-C-P000-P000-Z000-ZZ-00-A
5) End Cover	CLS102-FS-00-A
6) CLS180/2 Tie Rod Kit	6038226-002
6) CLS100/4 Tie Rod Kit	6038225-004
7) Paint	AU

Note: Repeat section model code for additional sections.

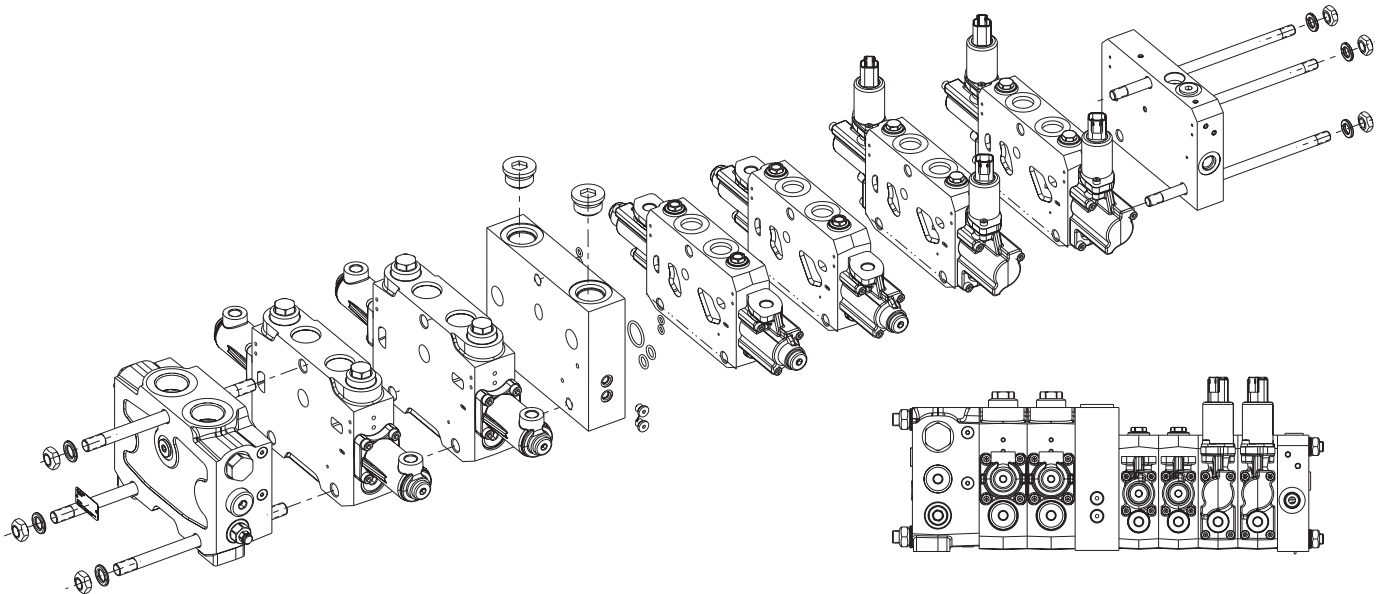

CLS180 Load Sense Sectional Mobile Valve

Tie Rod Kits

Tie rod kits are required to complete a valve bank assembly. Tie rod length depends on the number of

sections in the bank. Each tie rod kit includes three (3) tie rods, three (3) nuts and three (3) washers.

Tie Rod Kit	Desc.	PN	Length (mm)	Clamping Torque (Nm)
CLS100/1	1 Sect.	6038225-001	95	40
CLS100/2	2 Sect.	6038225-002	133	
CLS100/3	3 Sect.	6038225-003	172	
CLS100/4	4 Sect.	6038225-004	210	
CLS100/5	5 Sect.	6038225-005	248	
CLS100/6	6 Sect.	6038225-006	287	
CLS100/7	7 Sect.	6038225-007	324	
CLS100/8	8 Sect.	6038225-008	361	
CLS100/9	9 Sect.	6038225-009	400	
CLS100/10	10 Sect.	6038225-010	438	

Tie Rod Kit	Desc.	PN	Length (mm)	Clamping Torque (Nm)
CLS180/1	1 Sect.	6038226-001	176	70
CLS180/2	2 Sect.	6038226-002	222	
CLS180/3	3 Sect.	6038226-003	268	
CLS180/4	4 Sect.	6038226-004	314	
CLS180/5	5 Sect.	6038226-005	360	
CLS180/6	6 Sect.	6038226-006	406	
CLS180/7	7 Sect.	6038226-007	452	
CLS180/8	8 Sect.	6038226-008	498	
CLS180/9	9 Sect.	6038226-009	544	
CLS180/10	10 Sect.	6038226-010	590	

Transition Plates	Description	PN	Code	Coloring
CLS180/100	Electrohydraulic Adaptor Plate	6038080-001	AU	Standard Flat Black
CLS180/100	Hydraulic or Manual Adaptor Plate	6037913-001	00	No Paint

CLS180 Load Sense Sectional Mobile Valve

CLS180 with manual actuation and enclosed lever box

Units: mm

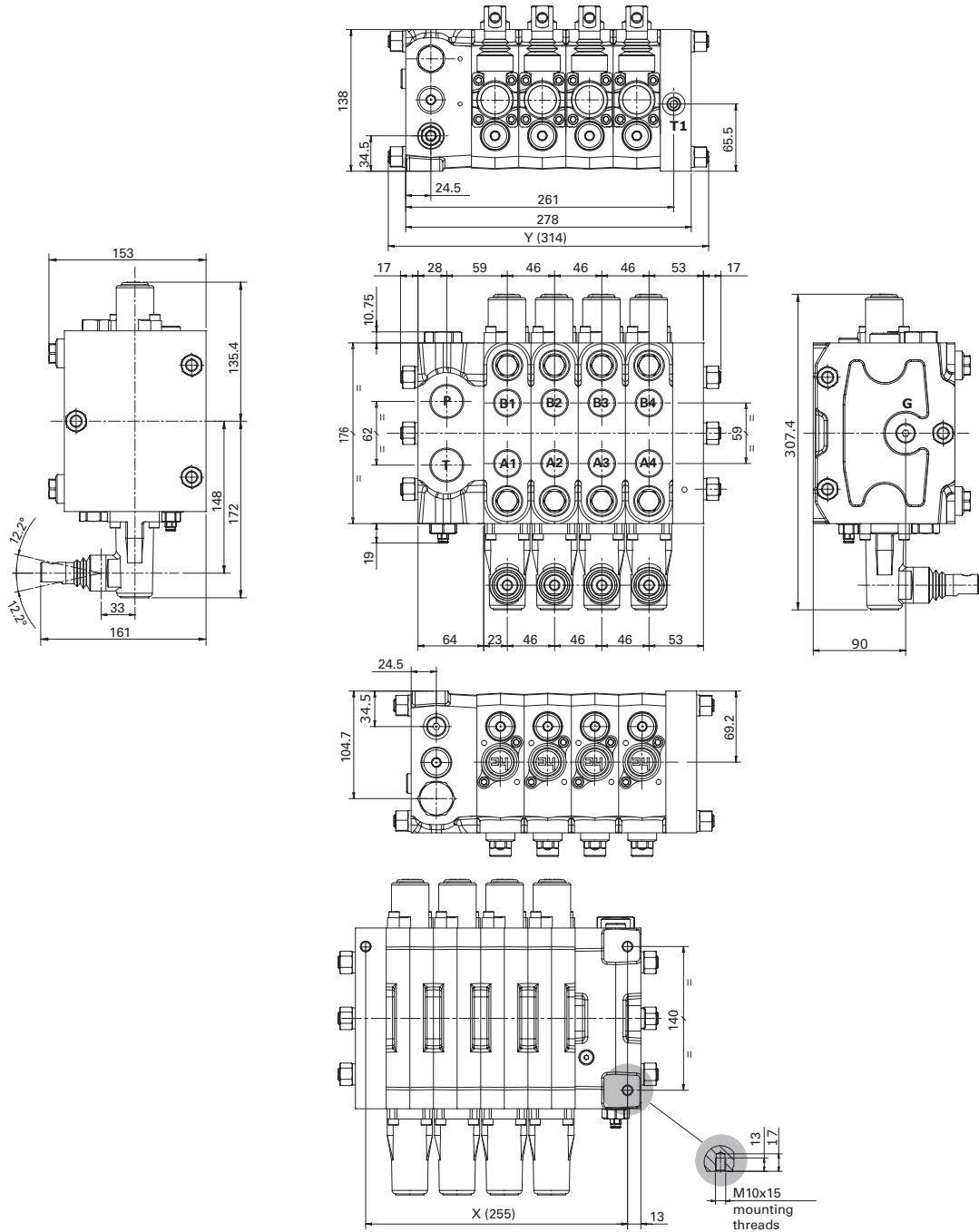

Dimension	Number of sections									
	/1	/2	/3	/4	/5	/6	/7	/8	/9	/10
X (mm)	117	163	209	255	301	347	393	439	485	531
Y (mm)	176	222	268	314	360	406	452	498	544	590
Weights (kg)	23.8	30	36.2	42.4	48.6	54.8	61	67.2	74.3	79.6

CLS180 Load Sense Sectional Mobile Valve

CLS180 with electrohydraulic actuation

Units: mm

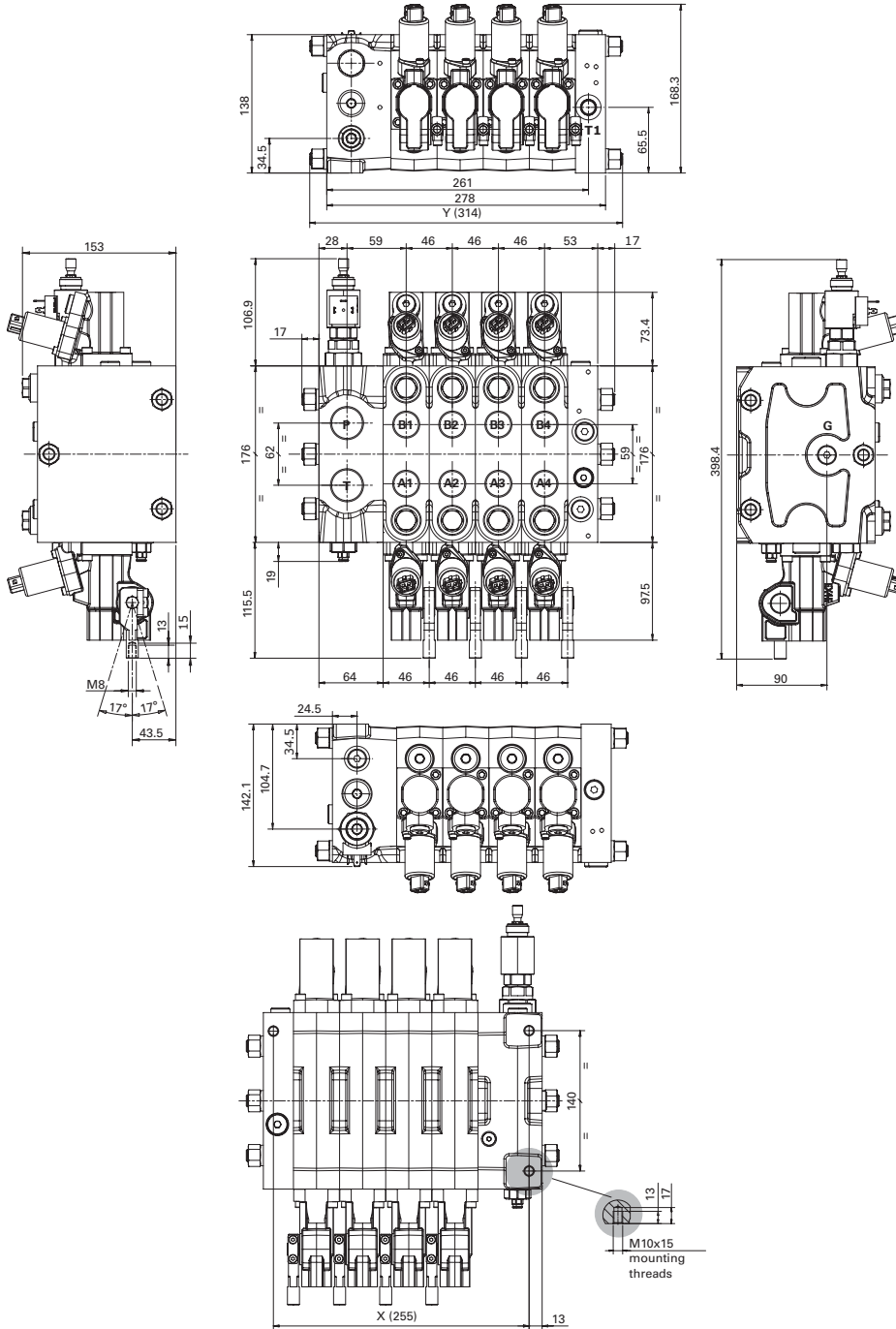

Dimension	Number of sections									
	/1	/2	/3	/4	/5	/6	/7	/8	/9	/10
X (mm)	117	163	209	255	301	347	393	439	485	531
Y (mm)	176	222	268	314	360	406	452	498	544	590
Weights (kg)	23.8	30	36.2	42.4	48.6	54.8	61	67.2	74.3	79.6

CLS180 Load Sense Sectional Mobile Valve

Typical curves

Inlet compensator pressure drop (P-T)

Fixed displacement system: pressure drop across the inlet compensator as function of pump flow

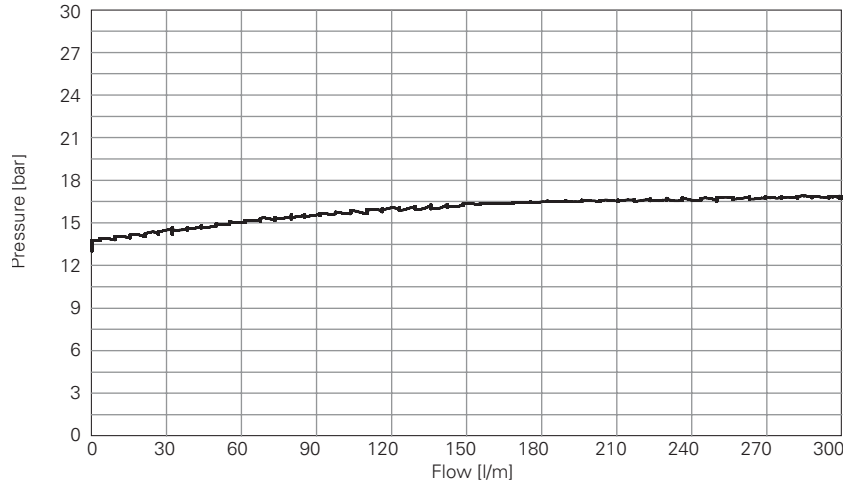

LS Signal pressure relief valve

Fixed displacement system: LS Signal pressure relief valve characteristic

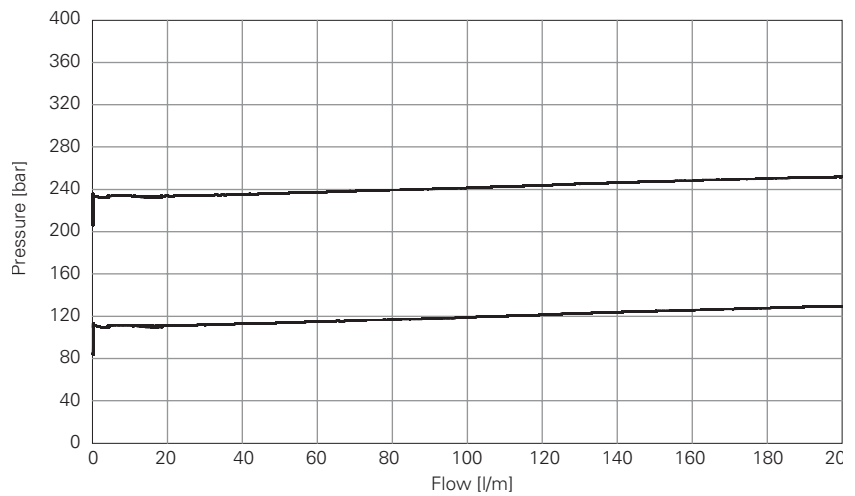

Full flow dump valve

Fixed displacement systems: pressure drop across open electric dump valve as function of pump flow

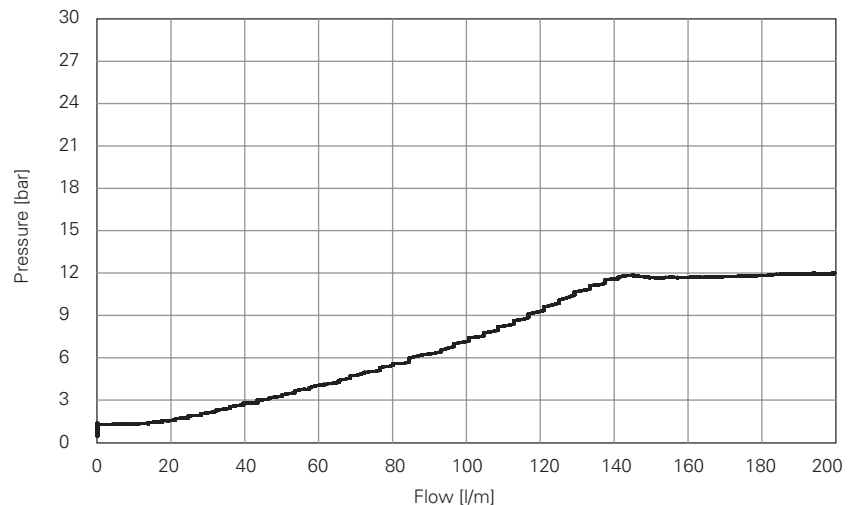

CLS180 Load Sense Sectional Mobile Valve

Typical curves

Post compensated spool flow characteristic

Fixed displacement systems: flow on ports A and B as function of spool stroke, pilot pressure, control current Inlet flow: 200 l/min

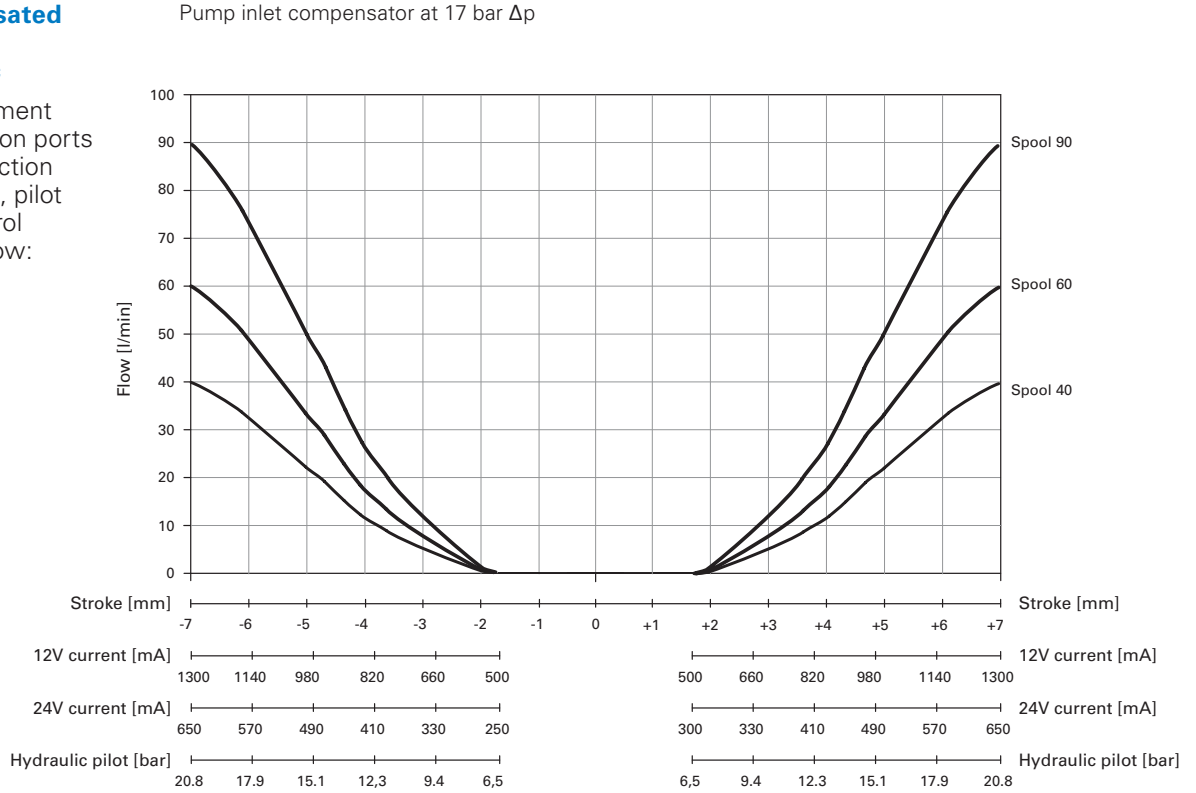

Post compensated spool flow with variable displacement pumps

Variable displacement systems: spools maximum delivered flow as function of pump ΔP setting

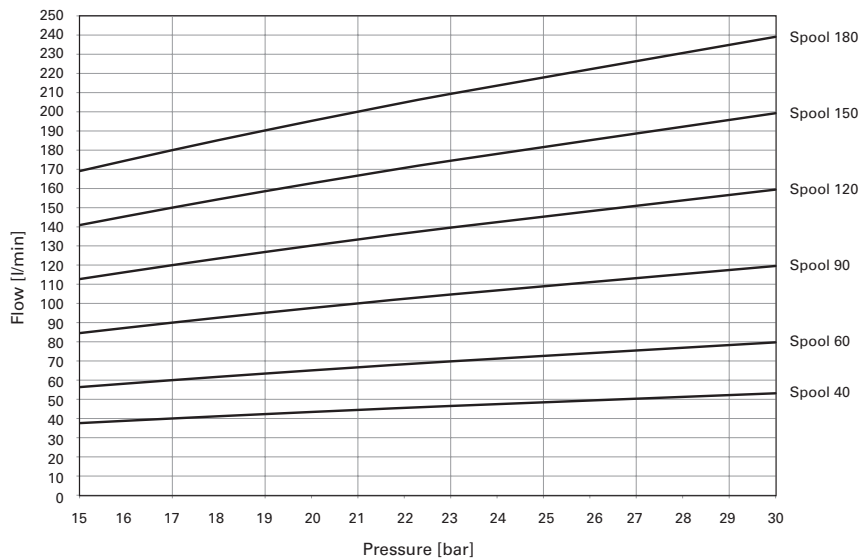

CLS180 Load Sense Sectional Mobile Valve

Typical work port auxiliary valve curves

Combined valves (relieving function)

Pressure characteristic as function of flow

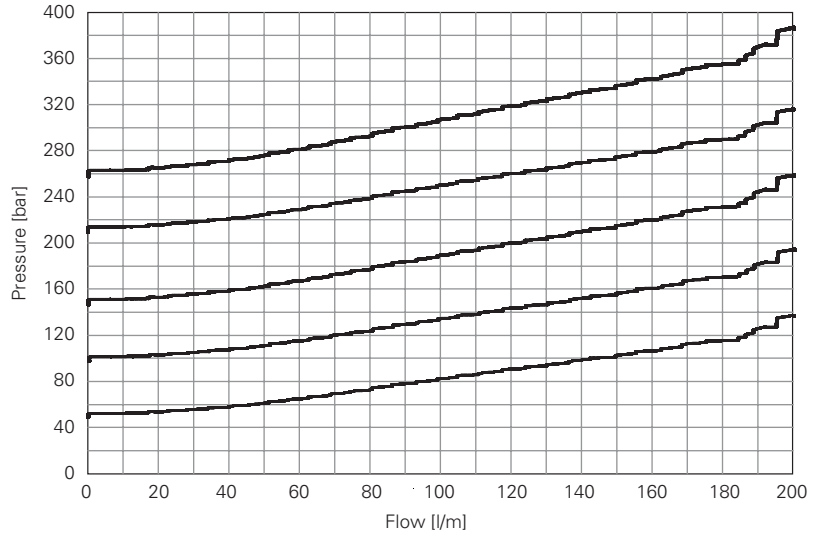

Combined valves (anticavitation function)

Opening and pressure characteristic as function of flow

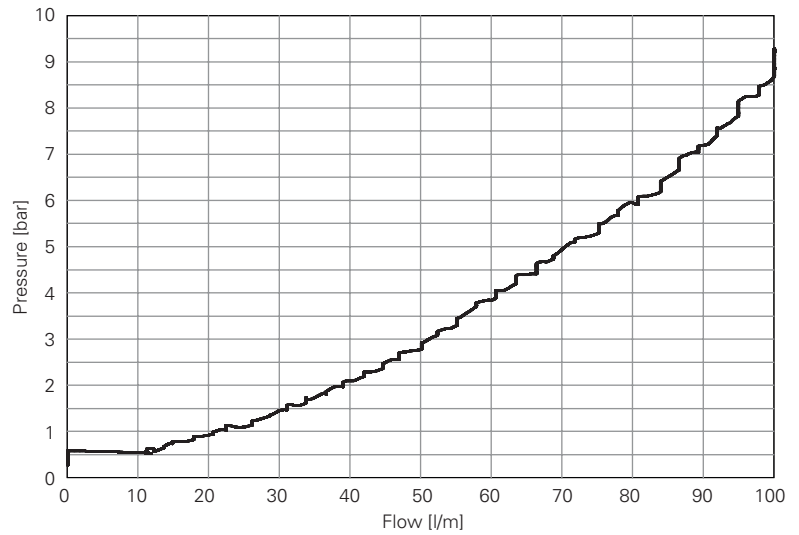

Model code for valve bank inlet

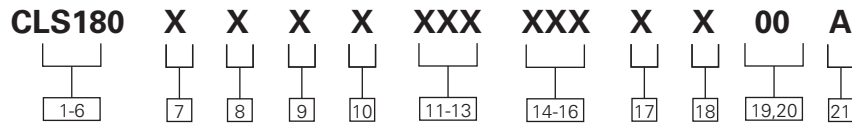

1-6 Product series

CLS180 – Load sense sectional mobile valve: standard valve bank inlet

7 Inlet build

R – Right hand build
L – Left hand build

8 Inlet type

L – Load Sensing
U – Unload for Open Center

9 Inlet ports

B – BSP (G3/4 P&T, G1/4 LS)
S – SAE (-12 P&T, -6 LS)

10 Inlet reliefs

D – LS & Full Flow Reliefs
L – LS Relief Only
R – Full Flow Relief Only
Z – No Reliefs

11-13 Load sense relief setting

XXX – 3 digit load sense relief setting in 5 bar increments, code 000 if none
Note: 50-350 bar
Requires minimum 40 bar difference in setting of full flow and LS relief valves.

14-16 Full flow relief setting

XXX – 3 digit full flow relief setting in 5 bar increments, code 000 if none
Note: 40-420 bar
Requires minimum 40 bar difference in setting of full flow and LS relief valves.
“Settings above 350 bar should be used with approval of duty cycle”

17 Inlet dump valve

F – Full flow dump valve
L – LS dump valve
Z – No dump valve

18 Inlet Coil

A – 12V Coil with DIN connector
B – 24V Coil with DIN connector
C – 12V Coil Deutsch connector
D – 24V Coil Deutsch connector
E – 12V Coil AmpJr connector
F – 24V Coil AmpJr connector
Z – No coil

19-20 Special features

00 No special features

21 Design level

A – Initial release

CLS inlet - Build and type

Dimensions and configurations for model code positions 9 & 10

R - Right hand build

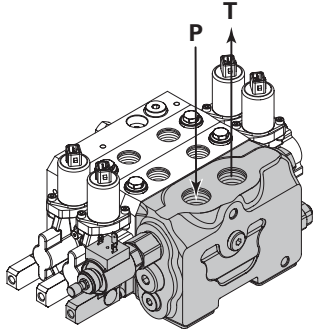

L - Left hand build

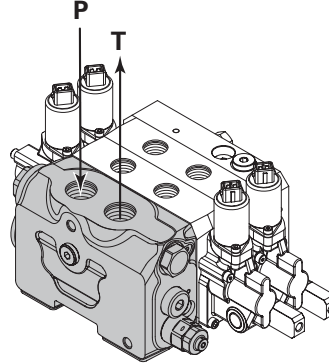

L - Load sensing

Closed center inlet section for variable displacement pumps

The inlet section with L configuration enables control valve usage with variable displacement pumps. With this configuration the presence of LS relief valve (A) is suitable to adjust the system maximum pressure. LS electric dump valve (C) can also be added as safety device. An additional full flow relief valve can be added to protect the system from pump regulator failures. An additional solution for variable displacement pumps is available on request to allow a constant reduced free flow in stand by condition through the system: this is sometimes required to guarantee a stand by flow for oil cooling.

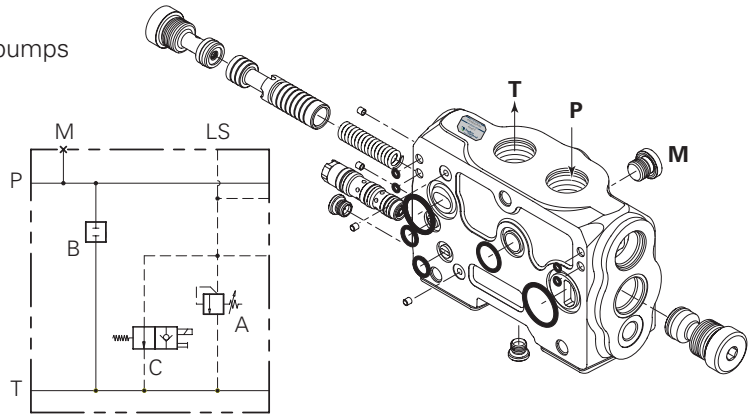

U - Unload for open center

Open center inlet section for fixed displacement pumps

The inlet section with U configuration enables control valve usage with fixed displacement pumps. With this configuration the presence of LS relief valve (A) is suitable to adjust the system maximum pressure. Full flow electric dump valve (C) can also be added as safety device.

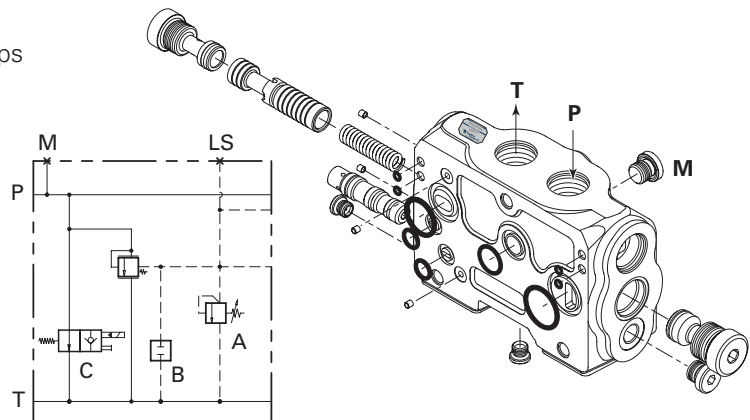

CLS inlet - Relief valve options

Schematics and configurations for model code position 12

D - LS and full flow reliefs

Note:

This combination requires that the Full Flow Relief be set at least 40 bar higher than the LS Relief.

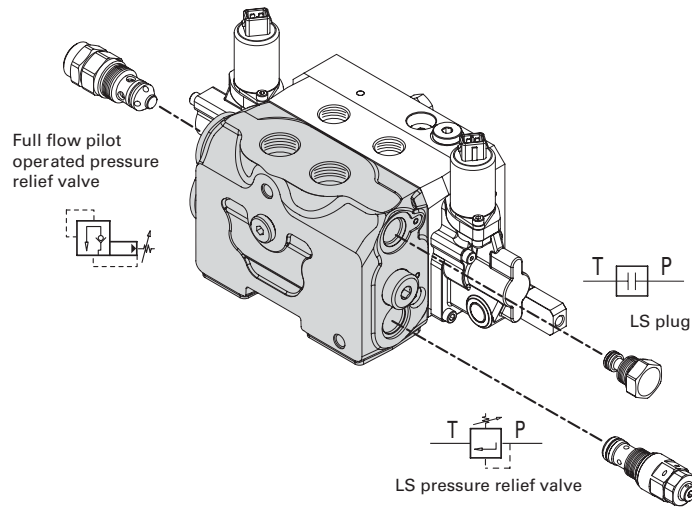

L - LS relief only

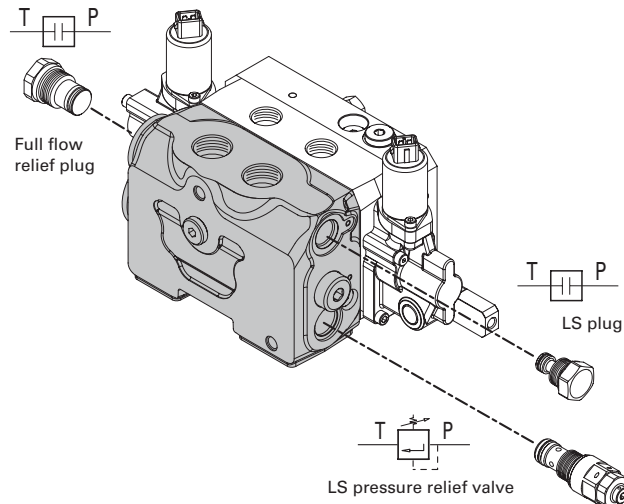

Z - No reliefs

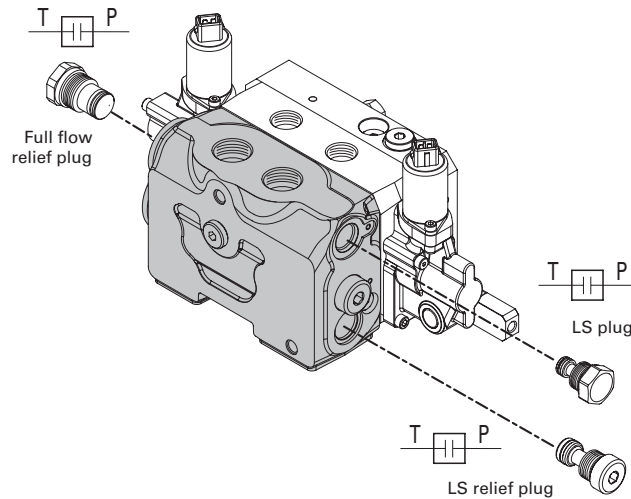

CLS inlet - Dump valve options

Model code positions 19 & 20

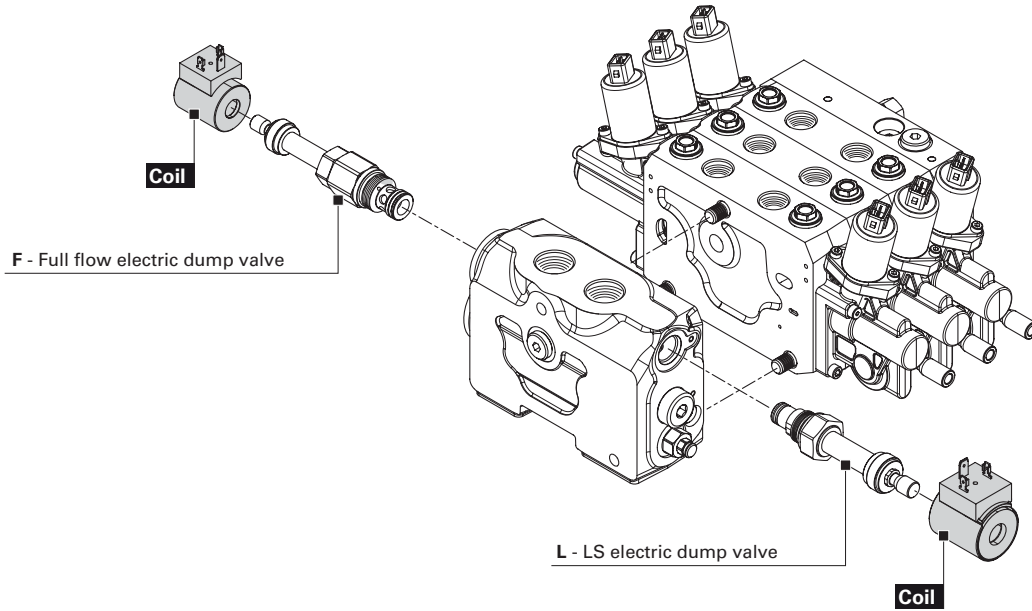

Coil and Connectors specifications for inlet section

Option	Supply voltage (VDC)	Connector	Ingress Rating	Coil resistance R20 (Ω)	Connector material	Coil body	Duty cycle	Coil Insulation	Power
A	12	12	IP 65	7	Nylon	Zinc plated steel	ED 100%	Class H coil - IEC 85 Standard (200°C)	20.5 W
B	24	24	IP 65	28					
C	12	12	IP 67	7					
D	24	24	IP 67	28					
E	12	12	IP 65	7					
F	24	24	IP 65	28					

F - Full Flow Dump Valve

L - LS Electric Dump Valve

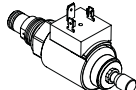
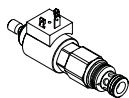

Model code for sections

The following 35 digit coding system has been developed to identify preferred feature options for the CLS180 Load Sense Sectional Mobile Valve series. Use this code to

specify a valve with the desired features. All 35-digits of the code must be present to release a new product number for ordering.

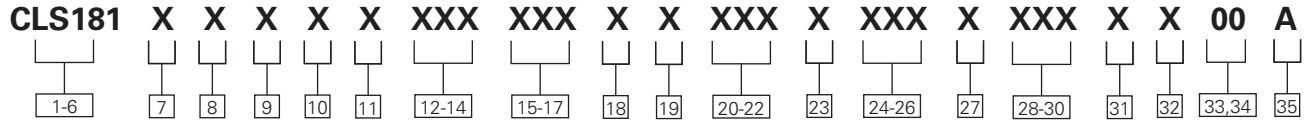

1-6 Product series

CLS181 – Load sense sectional mobile valves

7 Compensation

- P** – Post-compensated
- R** – Post-compensated with local flow limiter

8 Actuation

- A** – Hydraulic with top ports
- C** – Hydraulic with end ports
- E** – Electrohydraulic with lever override
- F** – Electrohydraulic only
- L** – Manual with enclosed lever box
- M** – Manual with exposed spool connection
- N** – Manual with pneumatic pilot, pneumatic ports downward
- P** – Manual with pneumatic pilot, pneumatic top ports

9 Port type

- B** – G3/4 BSP (G1/4 Pilot if Hyd., G1/8 if Pneumatic)
- S** – SAE, -12 (SAE -6 Pilot if Hyd., 1/8 NPTF if Pneumatic)

10 Spool type

- D** – Double acting (4 way) cylinder
- H** – Bi-directional (4 way) motor, full open to tank in neutral

11 Spool action

- A** – Spring centered to neutral
- B** – Detent “in” and “out”

12-14 Port A spool flow

- 040** – 40 l/m
- 060** – 60 l/m
- 090** – 90 l/m
- 120** – 120 l/m
- 150** – 150 l/m
- 180** – 180 l/m

15-17 Port B spool flow

- 040** – 40 l/m
- 060** – 60 l/m
- 090** – 90 l/m
- 120** – 120 l/m
- 150** – 150 l/m
- 180** – 180 l/m

18 Coil type

- C** – 12V coil Deutsch connector
- D** – 24V coil Deutsch connector
- E** – 12V coil AmpJr connector
- F** – 24V coil AmpJr connector
- Z** – No coil

19 Port A option function

- A** – Anti-cav
- R** – Relief/Anti-cav
- P** – Plugged - work port of LSrelief cavities machined and plugged
- Z** – None - no work port or LS relief machining

20-22 Port A option setting

- XXX** – 040-350 (3 digit, in 10 bar increments), relief valve pressure setting, port A

23 Port B option function

- A** – Anti-cav
- R** – Relief/Anti-cav
- P** – Plugged - work port of LS relief cavities machined and plugged
- Z** – None - no work port or LS relief machining

24-26 Port B option setting

- XXX** – 040-350 (3 digit, in 10 bar increments), relief valve pressure setting, port B

27 LS Relief Setting

- P** – Post comp - section load sense relief (applies to both A and B ports)
- R** – Post Comp - SAE -6 or G1/4 port for remote load sense relief (applies to both A and B Ports)
- Z** – No LS relief

28-30 LS relief setting

- XXX** – 3 digit section LS relief setting in bar (000 if not present or if using remote is relief)

31 Spool stroke limiter or position indicator

- A** – Electrohydraulic section w/spool stroke limiter
- B** – Hydraulic section w/spool stroke limiter
- Z** – None

32 Lever kits

- A** – 135mm (5.5”) lever kit
- B** – 210mm (8.5”) lever kit
- Z** – None

33,34 Special features

- 00** – No special features

35 Design level

- A** – Initial release

Valve section options - Compensation

Model code position 7

P - Post-compensated (flow sharing)

Available with or without auxiliary valve cavities

Note: Shown with auxiliary valves

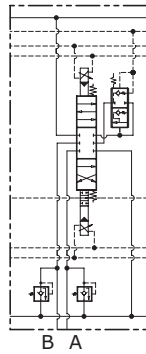
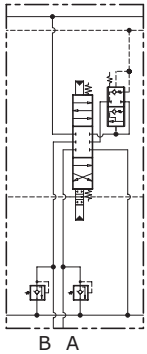

Mechanical lever acuation Electrohydraulic acuation

R - Post-compensated (flow sharing) with local flow limiter

Available with or without auxiliary valve cavities

Note: Shown with auxiliary valves

Requires right valve bank inlet selection

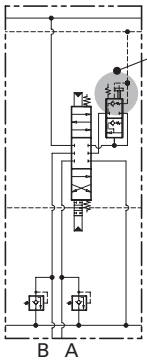

Compensator kit with local flow limiter

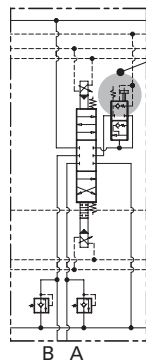

Compensator kit with local flow limiter

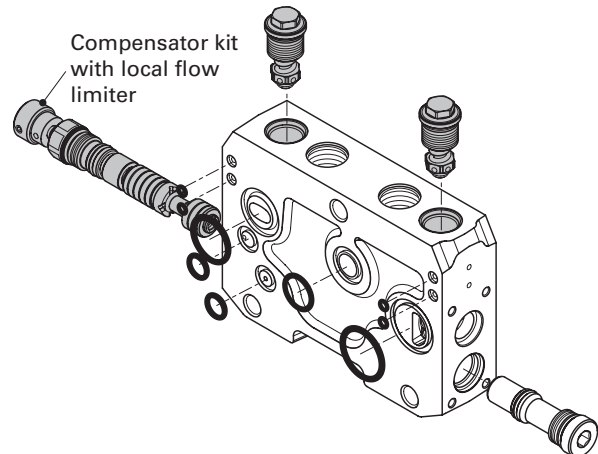

Mechanical lever acuation Electrohydraulic acuation

Valve section options - Actuation for hydraulic control

Dimensions and configurations for model code position 8

Units: mm

A - Hydraulic with top ports

Hydraulic actuation (pilot ports on the top) (Only with manual and hydraulic section body)

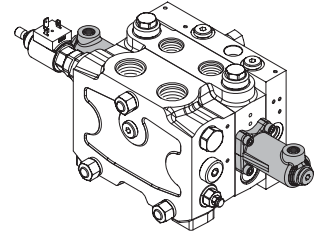
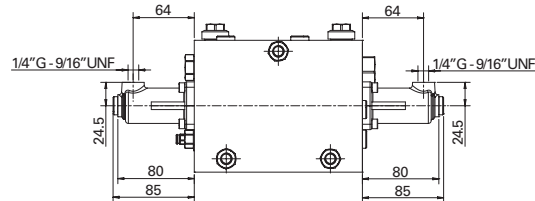

C - Hydraulic with end ports

Hydraulic actuation (pilot ports on the sides) (Only with manual and hydraulic section body)

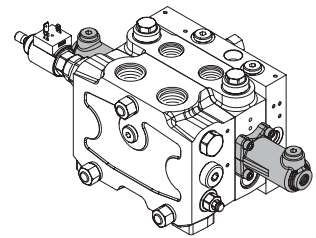
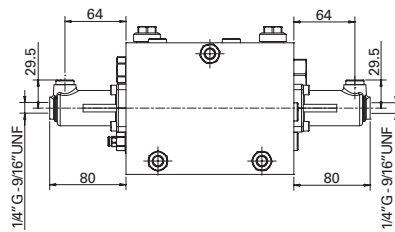

Valve section options - Actuation for electrohydraulic control

Dimensions and configurations for model code position 8

Units: mm

E - Electrohydraulic with lever override

Note: Includes solenoid operated pilot valve

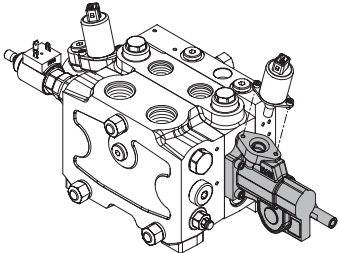
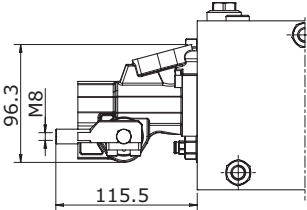

F - Electrohydraulic only

Without Lever

Note: Includes solenoid operated pilot valve

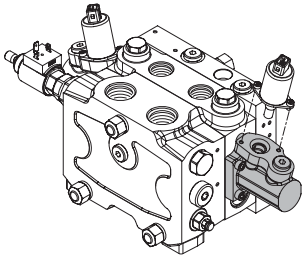
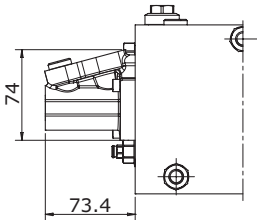

Valve Section Options - Actuation for manual control

Dimensions and Configurations for Model Code Position 8

Units: mm

L - Manual with enclosed lever box

Lever actuation (Only with manual and hydraulic section body)

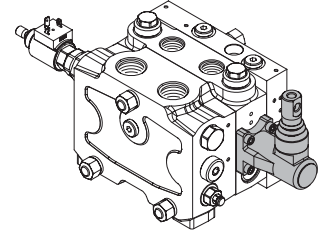
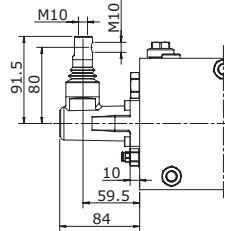

M - Manual with exposed spool connection

Without lever actuation (Only with manual and hydraulic section body)

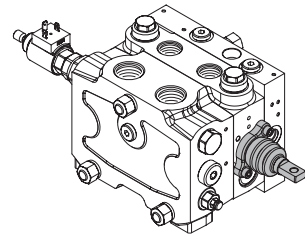
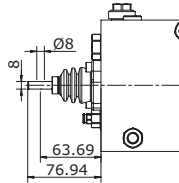

N - Manual with pneumatic pilot, pneumatic ports downward 180°

Note: Only available on post-compensated sections

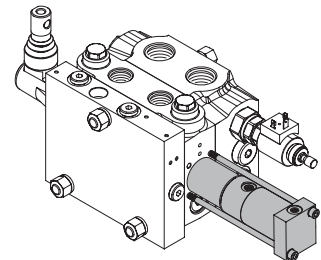
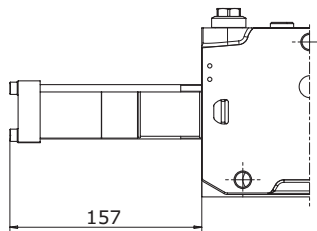

P - Manual with pneumatic pilot, pneumatic top ports

Note: Only available on post compensated sections

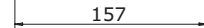

Valve section options - Spool type

Model code position 10

D - Double acting (4 way) cylinder

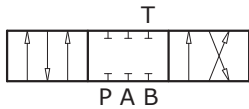

H - Bi-directional (4 way) motor, full open to tank in neutral

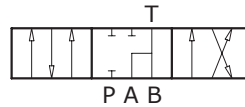

Valve section options - spring action options

Model code position 11

A - Spring Centered in Neutral

B - Detent "in" and "out"

Note: This option only available with post-compensation

Valve Section Options - Port A and Port B spool flows

Model Code Positions 12-14 (Port A) &
Model Code Positions 15-17 (Port B)

Post-compensated section

Spool Type	Flow Rates (l/min)					
	040	060	090	120	150	180
D	•	•	•	•	•	•
H	•	•	•	•	•	•

Note: Rated flows are defined for 17 bar Δp .

Listed flows are for symmetrical spools; for questions regarding asymmetric spools please contact your sales representative.

Valve Section Options - Coil Voltage and Connector

Model Code Position 18

Coil and connector specifications

Option	Supply Voltage (Vdc)	Connector	Ingress rating	Coil Resistance R20 (Ω)	Feeding reducing pressure	Prop. Current control (mA)	On-off current control (mA)	PWM suggested frequency (hz)
C	12	Deutsch DT4	IP 67	4.7	40 bar	600-1300	2500	70-90
D	24	Deutsch DT4	IP 67	20.8		300-650	1150	
E	12	Amp Jr	IP 65	4.7		600-1300	2500	
F	24	Amp Jr	IP 65	20.8		300-650	1150	

Valve Section Options - Port A and Port B functions and settings

Model code positions 20-26

A - Anti-Cav

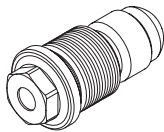

R - Relief/Anti-Cav

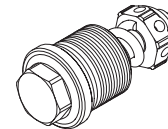

Note: Factory setting 40-350 bar

P - Plugged - Work port of LS relief cavities machined and plugged

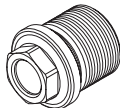

Valve section options - Load sense relief setting

Model code position 28

R - Post-comp - Port for remote load sense relief (applies to both A & B Ports)

Schematic for
Manual control

Schematic for
Electrohydraulic control

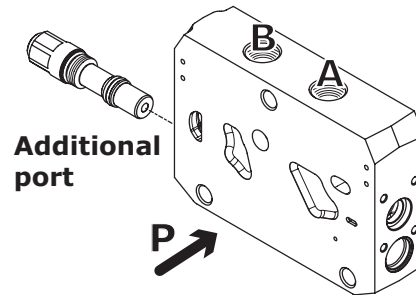
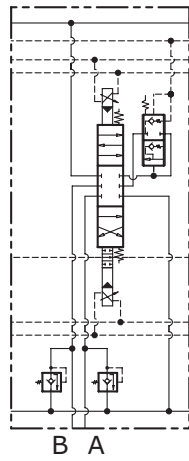
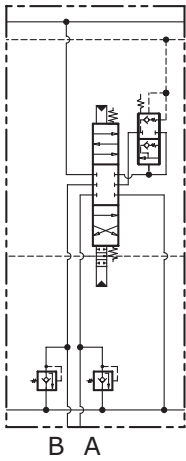

Note: Post comp load sense relief range is 0-350 bar.

Requires left valve bank inlet selection

P - Post-compensated - Section load sense relief (applies to both A & B ports)

Schematic for
Manual control

Schematic for
Electrohydraulic control

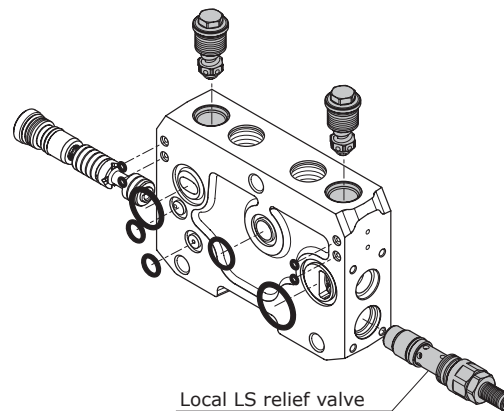
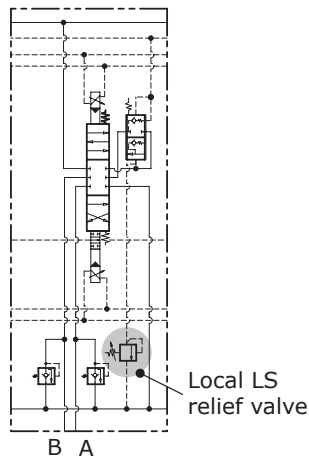
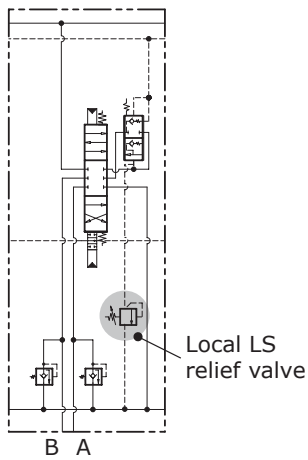

Note: Post-comp load sense relief range is 0-350 bar.

Requires left valve bank inlet selection

Valve section options - Spool stroke limiter or position indicator

Dimensions and configurations for model code position 32

Units: mm

A - Electrohydraulic section with spool stroke limiter

with lever override

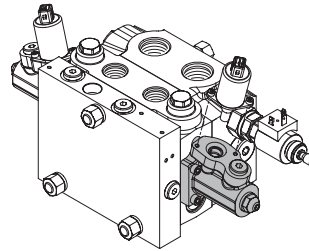
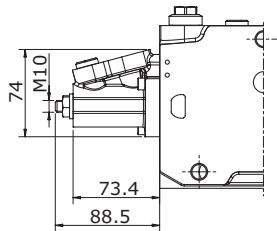

Note: Can be applied to sections with lever override

B - Hydraulic section with spool stroke limiter

Hydraulic actuation with stroke limiter

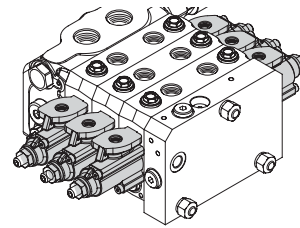
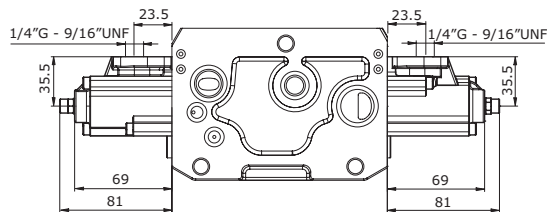

Valve section options - Lever kits

Model code position 33

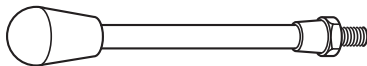

A - 135 Lever Kit

Lever with knob - 135mm (5.5")

B - 210 Lever Kit

Lever with knob - 210mm (8.5")

Model code for valve bank end cover

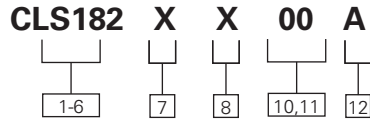

1-6 Product series

CLS182 – load sense sectional mobile valves

7 End cover

- F** – Electrohydraulic with external side drain
- G** – Electrohydraulic with external end drain
- H** – Hydraulic or manual with internal drain
- K** – Hydraulic or manual with external drain

8 End cover ports

- B** – BSP (G1/4 pilot drain)
- S** – SAE (-6 pilot drain)

12 Design level

- A** – Initial release

10,11 Special features

- 00** No special features

There are two types of End Covers:

Manual and Hydraulic actuation version

To be used when no electrohydraulic controls are present in the valve bank. This cover is simply collecting the LS signal drain that can be connected to tank internally or externally.

Electrohydraulic version

To be used when at least one section in the valve bank has electrohydraulic actuation. This cover is collecting LS signal and electrohydraulic pilot control drain and is providing electrohydraulic actuation by way of a pressure reducing valve.

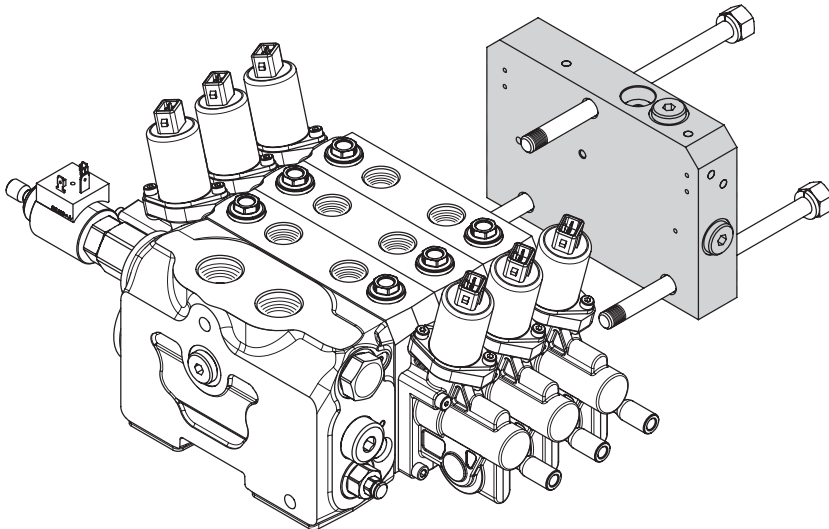

IMPORTANT: With electrohydraulic actuation, only an external drain is provided. It is recommended that the drain be connected directly to tank without any additional pressure drop, in order to avoid damage to the control system and poor control performance.

CLS assembly- End covers

Schematics and configurations for model code position 7

F - Electrohydraulic with external side drain

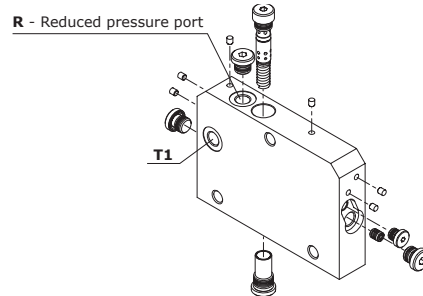
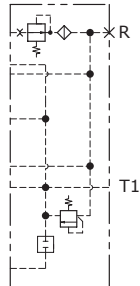

G - Electrohydraulic with external end drain

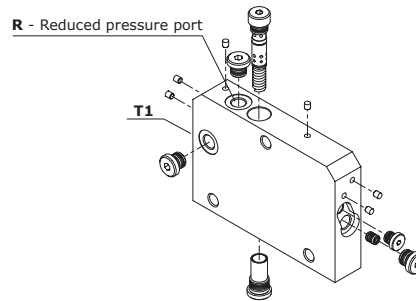
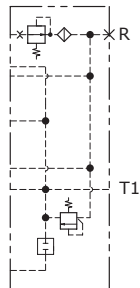

H - Hydraulic or manual with internal drain

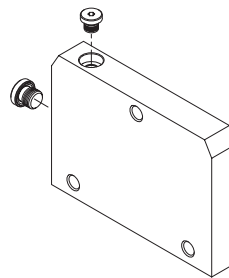
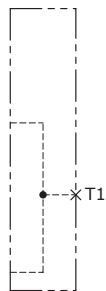

K - Hydraulic or manual with external drain

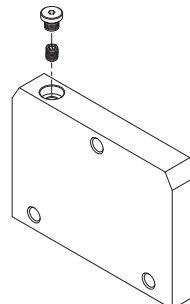
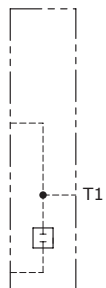

Flow sharing valves - Special features

Parallel connection of several valves

Thanks to a well thought out construction design, it is possible to obtain parallel connection of several control valves without the flow sharing function efficiency and simultaneity of movement being affected. The circuit is available either for fixed or variable pump, requires P, T and LS signal connection according to the following diagram.

This solution is especially successful in power-beyond situations where multiple applications are run on a single pump circuit.

Some examples include:

- Port and starboard **loading cranes** on commercial fishing vessels
- Tandem **forestry grapples**
- **Refuse truck** circuits

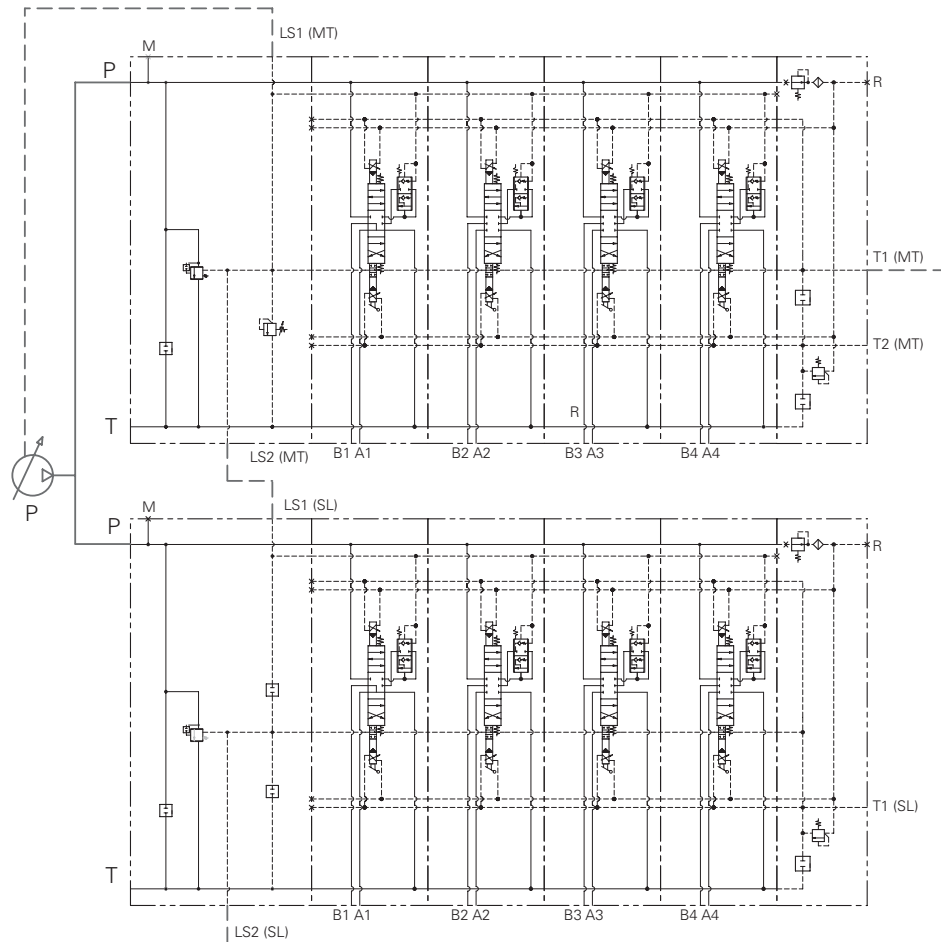
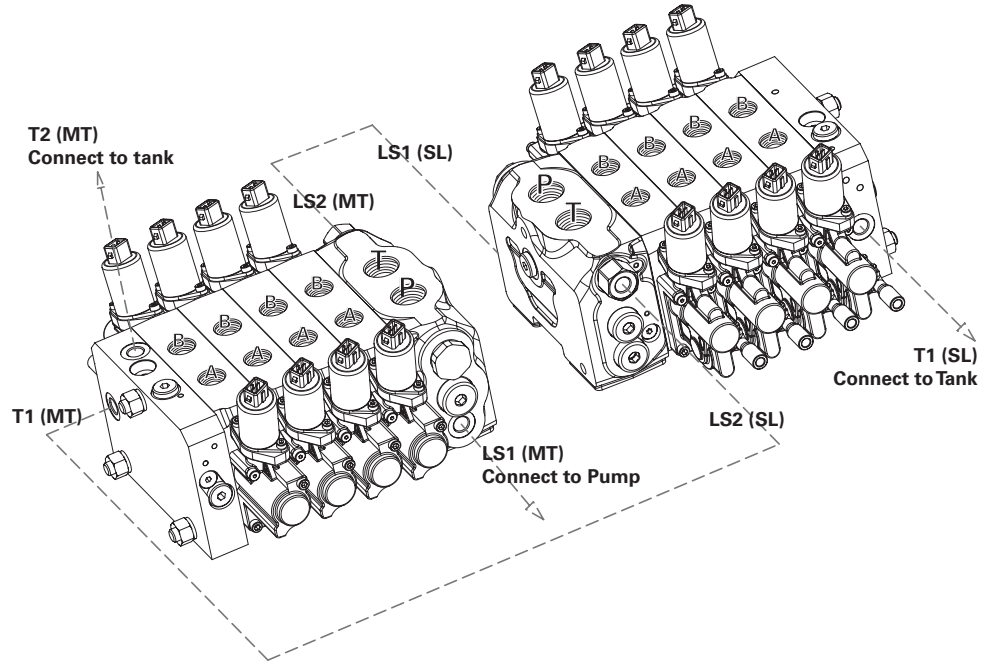

Flow sharing valves - Special features

High pressure carry over function

The carry over function is another clever option offered by the CLS family. In fixed displacement pump circuits, two control valves connected in succession can be used to ensure flow through the compensator on each valve bank.

This design is obtained by using a special inlet cover on the first valve.

This circuit is ideally suitable for **trailer-equipped machines** and **towed implements**, since the connection between the two control valves is achieved by simply using one pipe for P and one pipe for T (no additional LS signal connections are necessary).

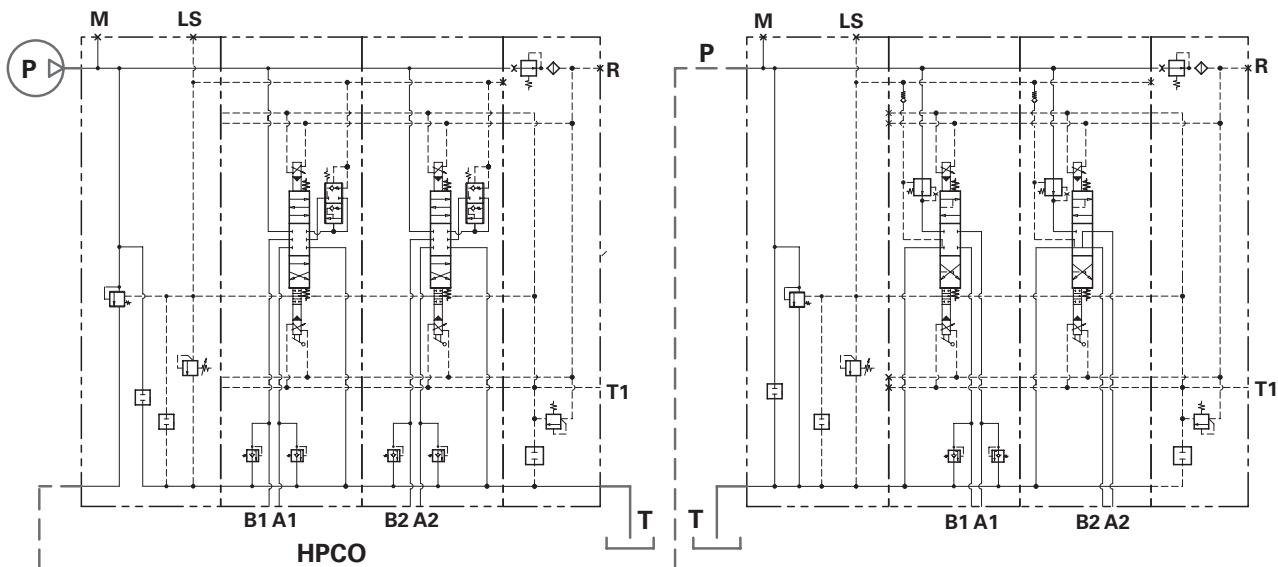
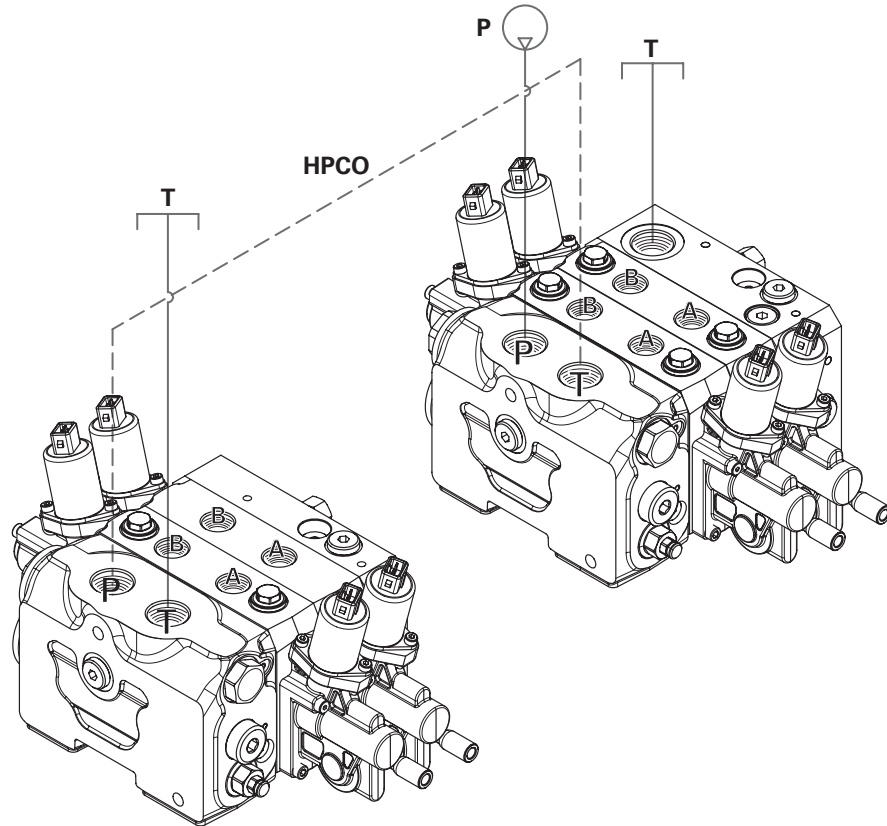

General torque specifications

The following pictures provide the main torque specifications for the CLS180. The three drawings depict the inlet section, the working section and the end cover plate.

Inlet section

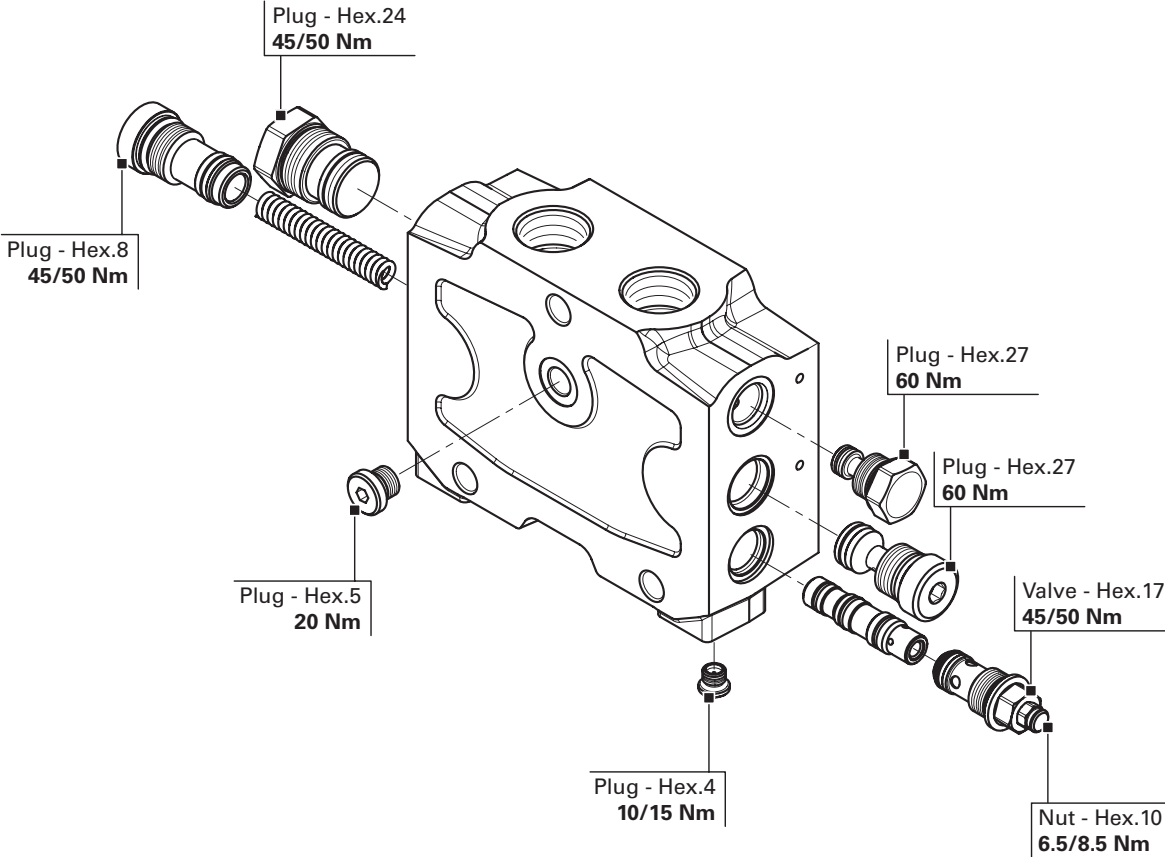

General torque specifications

The following pictures provide the main torque specifications for the CLS100. The three drawings depict the inlet section, the working section and the end cover plate.

Valve section

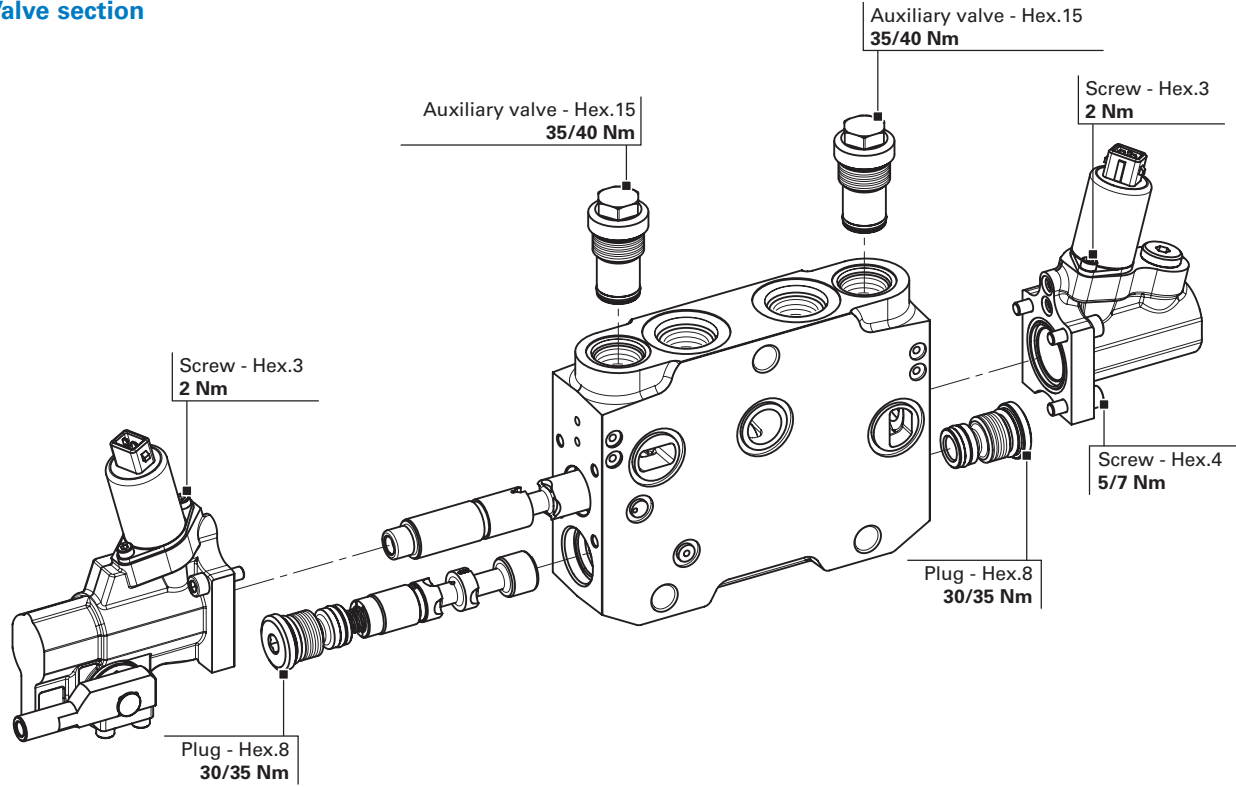

End cover section

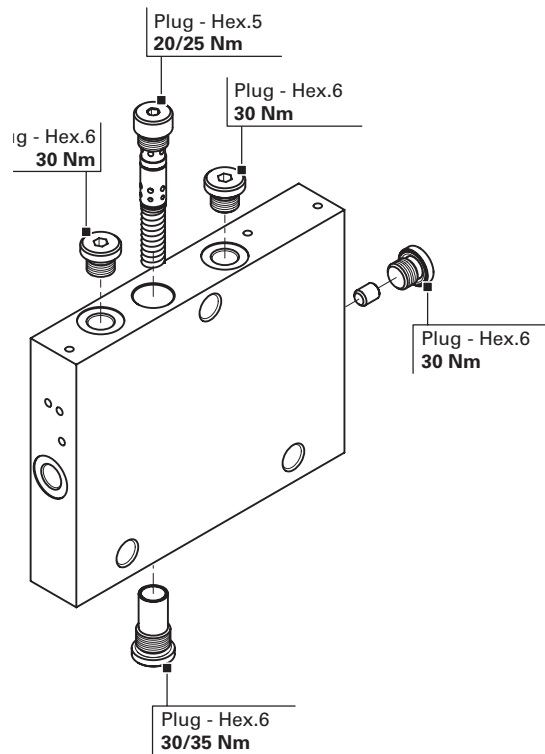

Hydraulic fluid recommendations

Introduction

Oil in hydraulic systems performs the dual function of lubrication and transmission of power. It is a vital element in a hydraulic system, and careful selection should be made with the assistance of a reputable supplier. Proper selection of oil assures satisfactory life and operation of system components, especially hydraulic pumps and motors.

Generally, oil selected for use with pumps and motors is acceptable for use with valves. Critical servo valves may need special consideration.

When selecting oil for use in an industrial hydraulic system, be sure the oil:

- Contains the necessary additives to ensure excellent anti-wear characteristics
- Has proper viscosity to maintain adequate sealing and lubrication at the expected operating temperature of the hydraulic system
- Includes rust and oxidation inhibitors for satisfactory system operation

Types of hydraulic fluids

Hydraulic fluids are classified by the type of base stock used. Some fluids are further classified by fluid formulation and performance.

Anti-wear hydraulic fluids

For general hydraulic service, Eaton recommends the use of mineral base anti-wear (AW) hydraulic oils meeting Eaton specification

E-FDGN-TB002-E.

Eaton requests that fluid suppliers test newly developed lubricants on Eaton 35VQ25A high pressure vane pump, according to Eaton ATS-373 test procedure, ASTM D 6973 test method and meet other requirements of the Eaton specification E-FDGN-TB002-E.

Lubricants meeting the Eaton specification are considered good quality anti-wear hydraulic fluids that can be used with Eaton components at maximum allowable operating conditions. They offer superior protection against pump wear and long service life.

Crank case oils

Automotive-type crankcase oils with American Petroleum Institute (API) letter designation SE, SF, SG, SH or higher per SAE J183 classes of oils are recommended for hydraulic service. The “detergent” additive tends to hold water in a tight emulsion and prevents separation of water.

Automotive type crankcase oils generally exhibit less shear stability, which can result in higher loss of viscosity during service life.

Multiple-viscosity, industrial grade hydraulic fluids with better shear stability will provide improved viscosity control. Other mineral oil based lubricants commonly used in hydraulic systems are automatic transmission fluids (ATFs) and universal tractor transmission oils (UTTOs).

Synthetic hydrocarbon

Synthetic hydrocarbon base stocks, such as polyalphaolefins (PAOs), are also used to formulate AW hydraulic fluids, crankcase oils, ATFs and UTTOs.

Environmentally friendly hydraulic fluids

Eco-friendly characteristics is becoming a critical need, and a number of biodegradable hydraulic fluids are being used more and more in environmentally sensitive areas.

Biodegradable hydraulic fluids are generally classified as vegetable oil based (HETG), synthetic ester (HEES), polyalkylene glycol (HEPG) and polyalphaolefin (HEPR). In addition, special water glycol hydraulic fluids are used in applications in which water miscibility is necessary, along with biodegradable properties.

Fire-resistant hydraulic fluids

Fire-resistant fluids are classified as water containing fluids or synthetic anhydrous fluids. Water acts as the fire retarding agent in water containing fluids. The chemical structure of synthetic anhydrous fluids provides fire resistance.

Many applications that are prone to fire hazard, such as steel mills, foundries, die casting, mines, etc., require the use of fire resistant hydraulic fluid for improved fire safety. Fire resistant fluids may not be fireproof, but they have better fire resistance compared to mineral oil.

The alternative fluids are

recommended when specific properties, such as fire resistance, biodegradability etc., are necessary for the application. Keep in mind that alternative fluids may differ from AW petroleum fluids in properties such as pressure viscosity coefficient, specific gravity, lubricity etc. Hence certain pumps / motors may need to be de-rated, some can be operated under full ratings and others are not rated. Be sure to confirm product ratings with the specific fluid in the intended application.

Viscosity

Viscosity is the measure of a selection of hydraulic fluid with a specific viscosity range should be based on the needs of the system, limitations of critical components, or proper performance of specific types of units. At system startup and during operation, Eaton recommends maintaining the fluid’s maximum and minimum viscosity ranges (see chart). Very high viscosities at startup temperatures can cause noise and cavitation damage to pumps.

Continuous operation at moderately high viscosities will tend to hold air in suspension in the fluid, as well as generate higher operating temperatures. This can cause noise, early failure of pumps and motors and erosion of valves. Low viscosities result in decreased system efficiency and impairment of dynamic lubrication, causing wear.

It is important to choose the proper fluid viscosity

Hydraulic fluid recommendations

for your particular system in order to achieve the startup viscosity and running viscosity range (see chart) over the entire temperature range encountered. Confirm with your fluid supplier that the fluid viscosity will not be less than the minimum recommended at the maximum fluid temperature of your application.

A number of anti-wear hydraulic fluids containing polymeric thickeners (Viscosity Index Improvers [VII]) are available for use in low temperature applications. Temporary or permanent viscosity loss of some of these fluids at operating temperature may adversely affect the life and performance of components. Before using polymer containing fluids, check the extent of viscosity loss (shear stability) to avoid hydraulic service below the recommended minimum viscosity. A fluid with good shear stability is recommended for low temperature applications.

Multi-grade engine oils, ATFs, UTTOs etc., also contain VIIs, and viscosity loss will be encountered during use.

Cleanliness

Fluid cleanliness is extremely important in hydraulic systems. More than 70% of all failures are caused by contamination, which can reduce hydraulic system efficiency up to 20% before system malfunction may be recognized. Different hydraulic components require different cleanliness levels. The cleanliness of a hydraulic system is dictated by the cleanliness requirement of the most stringent component in the system. OEMs and distributors should provide their customers with cleanliness requirements for Eaton hydraulic components used in their system designs. Refer to Eaton product catalogs for specific cleanliness requirements of individual components.

Fluid maintenance

The condition of a fluid has a direct bearing on the performance and reliability of the system. Maintaining proper fluid viscosity, cleanliness level, water content, and additive level is essential for excellent hydraulic system performance. In order to maintain a healthy fluid, Eaton recommends performing periodic checks on the condition of the fluid.

System design considerations

When designing a hydraulic system, the specific gravity of the hydraulic fluid needs to be taken into consideration. If the specific gravity of the fluid is higher than that of mineral oil, be sure the reservoir fluid level is adequately above the pump inlet to meet the recommended inlet operating condition of minimum 1.0 bar absolute pressure at the pump inlet.

Filters

Proper filter type and size, which vary depending on the type of fluid used in a system, are essential for healthy system function. The primary types of filter materials are paper, cellulose, synthetic fiber, and metal.

Filter media, adhesive, and seals must be compatible with the fluid used in the system. To lengthen fluid change out intervals, special absorbent filter media may be used to remove moisture and acids from phosphate esters.

Seals/Elastomers

Select seal/elastomer materials that are suitable for the application, minimum and maximum operating temperature, and compatibility with the type of fluid used

in the hydraulic system. The effect of hydraulic fluid on a particular elastomer depends on the constituents of the fluid, temperature range, and level of contaminants.

Replacing hydraulic fluid

Although sometimes valid, arbitrary hydraulic fluid change-outs can result in wasting good fluid and unnecessary machine downtime.

A regularly scheduled oil analysis program is recommended to determine when fluid should be replaced. The program should include inspection of the fluid's color, odor, water content, solid contaminants, wear metals, additive elements, and oxidation products. Clean the system thoroughly and flush with fresh, new fluid to avoid any contamination with the previous fluid/lubricant. Replace all seals and filters with new, compatible parts. Mixing two different fluids in the same system is not recommended.

Contact your Eaton representative with questions concerning hydraulic fluid recommendations.

Viscosity requirements

Product Line	Minimum	Optimum Range	Maximum Allowed - Startup	Cleanliness Requirement (ISO 4406:99)
CMX, CML, and CLS Proportional Control Valves	6 cSt (45 SUS)	20-43 cSt (100-200 SUS)	2158 cSt (10,000 SUS)	18/16/14

Eaton
Hydraulics Group USA
14615 Lone Oak Road
Eden Prairie, MN 55344
USA
Tel: 952-937-9800
Fax: 952-294-7722
www.eaton.com/hydraulics

Eaton
Hydraulics Group Europe
Route de la Longeraie 7
1110 Morges
Switzerland
Tel: +41 (0) 21 811 4600
Fax: +41 (0) 21 811 4601

Eaton
Hydraulics Group Asia Pacific
Eaton Building
4th Floor, No. 3 Lane 280 Linhong Rd.
Changning District
Shanghai 200335
China
Tel: (+86 21) 5200 0099
Fax: (+86 21) 5200 0400